

Pellet stoves Fox IT



Partner for your home



USER AND SERVICE MANUAL

INSTRUCTIONS FOR CONNECTING, OPERATION, AND MAINTENANCE OF THE STOVE

TABLE OF CONTENTS

1.0 INTRODUCTION	3
2.0 UPDATING THE INSTRUCTIONS	3
3.0 PRECAUTIONS AND SAFETY	3
4.0. RESPONSIBILITIES OF THE MANUFACTURER	4
4.1. RESPONSIBILITIES OF THE INSTALLER	4
5.0 TECHNICAL CHARACTERISTICS	5
5.1 ACCESSORIES	5
5.2 ASSEMBLING THE CONTROL PANEL	5
5.3 TECHNICAL DESCRIPTION	5
5.4 TECHNICAL DATA AND DIMENSIONS	6
6.0 INSTALLATION SITE PREPARATION	7
6.1 GENERAL RULES	7
6.2 CONNECTION OF THE OUTER AIR PIPE	8
6.3 EXHAUST GAS SYSTEM	8
6.4 EXHAUST GASES AND INSTALLATION	8
6.5 USABLE PIPES	8
6.6 INSTALLATION SCHEMES	9
6.7 REAR END OF THE EXHAUST GAS PIPE	9
6.8 CONNECTION TO THE ELECTRICAL POWER SUPPLY	10
7.0 USAGE	10
7.1 IMPORTANT INSTRUCTIONS	10
7.2 SAFETY PRECAUTIONS	10
7.3 WARNING SAFETY MEASURES FOR STAFF	11
7.4 WARNING SAFETY MEASURES FOR THE USER	11
7.5 SAFETY GUIDILINES FOR IGNITION AND CLEANING OF THE STOVE	12
8.0 FUELS	13
9.0 TECHNICAL SPECIFICATIONS	13
10.0 ELECTRONIC COMPONENTS SCHEME	14
11.0 EXPLANATION OF THE ELECTRONIC CONTROL PANEL	15
12.0 PELLETS	19
12.1 STORAGE OF PELLETS	19
12.2 POURING THE PELLETS	19
13.0 CLEANING AND MAINTENANCE	20
13.1 CLEANING AND MAINTENANCE OF THE EXHAUST PIPE	20
13.2 CLEANING AND MAINTENANCE OF THE STOVE	20
13.3 PERIODICAL CLEANING	21
13.4 GENERAL CLEANING	21
14.0 POST SALE SUPPORT	22
15.0 FAILURES - CAUSES – SOLUTIONS	23
16.0 WARRANTY TERMS AND CONDITIONS	26

1.0 INTRODUCTION

Dear buyer, we thank you for choosing this product.

This product is made in accordance with the safety requirements specified by the relevant European directives. This manual is intended to owners, installers, users and maintenance personnel of this product and is an integral part of the product. If there are any doubts regarding the contents of this manual or of any explanation please contact manufacturer or an authorised service centre. No printing translation or reproducing of this manual is allowed without the permission of KOPER. The technical information, illustration and specification included in this manual may not be disclosed.

Do not operate the appliance if any of the instruction provided in the manual are not understood. KOPER reserves the right to modify the technical and/or functional specification of the stove at any time without prior note. By using this instruction manual you will learn how to use your pellet burning stove properly; please read it carefully before use.

This product is manufactured in accordance to the following directives and standards:

Directive **89/106/EEC** – Approximation of the laws, regulation and administrative provisions of the member states relating to construction products.

Directive **2004/108/EC** – Approximation of the laws of the member states related to electromagnetic compatibility.

Directive **2006/95/EC** – Electrical equipment designed for use within certain voltage limits. Directive **89/391/EEC** – Introduction of measures to encourage improvements in the safety and health of the workers at work.

Directive **85/374/EEC** – Approximation of the laws, regulations and administrative provisions of the members states concerning liability for defective products.

Directive **1999/374/EC** – Radio equipment and telecommunication terminal equipment and the mutual recognition of their conformity.

Standard **EN 14785/2006** Residential space heating appliances fired by wood pellets – Requirements and test methods.

2.0 UPDATING THE INSTRUCTIONS

This manual reflects a work of art at the moment when the stove was placed on the market. Therefore, we does not take into account the stoves that are already on the market with the appropriate technical documentation and considers them as defective or inadequate after any kind of modification, adaptation or application of new technologies to newly produced machines.

The contents of this manual should be carefully read and studied. It is necessary to strictly follow all the instructions given in this manual. All information contained in this manual is necessary for proper connection, use, and maintenance of your stove.

Therefore, this manual has to be carefully stored for the necessary instructions in the event of any problems or concerns.

If the stove is given or sold to another person, the new owner must also be given this instructions manual.

If you have lost your manual, we can provide you with a new one.

3.0 PRECAUTIONS AND SAFETY

The pellet stoves are designed to provide maximum safety and easy of operation. However it is necessary to observe the following safety guidelines to ensure an accident-free operation.

1. It is recommended that the authorized maintenance staff should make sure not to leave bare parts of the wires not completely inserted into the connectors, so that no live parts of the wires may contact other objects.
2. The installation should be performed by specially trained staff authorized by the manufacturer; after its completion, the staff is obliged to give to the end user a statement which states that the pellet stoves connected according to all applicable standards and that the staff takes over the complete responsibility for its installation.
3. It is important to observe all applicable national laws of the country where the product is to be installed.
4. The manufacturer does not bear any responsibility if the above stated obligations are not observed.
5. The Instruction manual is one inseparable part of the product. In case the Instruction manual is

missing or lost, the end users could have it provided by the seller.

6. This pellet stove should be used only for the purpose it is intended for.

7. The manufacturer does not bear any responsibility for damages suffered by people, animals or objects caused due to installation errors or improper use.

8. After removing the packaging, the user should check whether all the parts are in place and if any parts missing, the user should have the seller provide the missing parts.

9. Only original parts must be used for replacement of faulty ones. Please refer only to authorized service agents holding certificate for maintenance of equipment.

10. For proper operation of the product, it should be serviced once after consumption of 1800 kg certified pellets or once a year. The service should be performed by authorized staff. Otherwise, the warranty will become void.

For safety purposes, the following must be strictly observed:

- The pellet stove is not to be operated by children or disabled persons.
- It is forbidden to install the product in a toilet, damp spaces, such as laundry room, as well as to touch the pellet stove with wet hands or legs. Power supply socket with a ground terminal (safety socket) should provide to power the appliance.
- It is forbidden to change or cancel the safety precaution switch out an authorization by a authorized technician.
- Do not pull, tear, burn the cables coming out from the product even if it is off.
- Do not leave the packaging close to children or disabled persons.
- During the normal operation of the product, the door should be closed at all times.
- Avoid direct contact with hot parts of the product.
- Check if there are difficulties while turning the product on after a long period of non- operation (see chapter 6.0).
- The pellet stove is designed to work even in extreme weather conditions, however, in case of strong wind or frosty conditions, the safety systems might trigger on and shut the pellet stove off. In such case, the user should contact the authorized service. It is not advisable to disable or reset the safety devices on the user's discretion.

Fire extinguisher should be in reach in case of accidental occurrence of fire in the exhaust gas pipe.

4.0 RESPONSIBILITIES OF THE MANUFACTURER

In issuing these instructions, we accept no civil or legal liability, direct or indirect, due to:

Accidents caused by not respecting the standards and specifications given in this manual,

Accidents caused by improper handling or use of the stove by the user,

Accidents resulting from modifications and repairs, which were not approved by us,

Poor maintenance,

Unforeseen events,

Accidents resulting from the use of spare parts that were not original or not intended for these models of stoves.

Responsibility for connecting is fully assumed by the installer - contractor.

4.1 RESPONSIBILITIES OF THE INSTALLER

Installer's responsibility is to do all the tests of the flue pipeline, air supply, and all the things that are necessary for connecting (installing) your stove.

Installer's responsibility is to adjust the stove to local regulations which apply where the stove is connected (installed).

The use of the stove must be in accordance with the instructions for use and maintenance, as well as with all the security standards that are given by the local regulations that apply where the stove is connected (installed).

The installer has to check:

- The type of stove to be connected,
- Whether the room corresponds to the stove where the stove will be installed, which is expressed as the

minimum size required for installation, set forth by the manufacturer of the stove,

- Heat generator
- Manufacturer's instructions regarding the requirements of smoke removal systems (ducts and pipes for smoke exhaust),
- inner cross section of the chimney, the material out of which the chimney is made, uniform cross section,
- That there are no disturbances and obstacles in the chimney,
- Height and vertical extension of the chimney,
- Altitude at the place of connecting the stove,
- The existence and suitability of the protective cover for the chimney that is resistant to the wind,
- The possibility of securing the external air supply and the size of the necessary openings,
- Simultaneous use of stove that needs to be connected with other equipment that already exists at that place. If the results of all checks are positive, then we can proceed with connecting the stove. Make sure you follow the instructions of the manufacturer of the stove, as well as the standards for fire protection and the safety standards provided.

When you are finished connecting, the stove has to be turned on in trial mode for at least 30 minutes to test if the stove is working properly.

When the installation and important details are completed, the installer must provide the client the following:

- Instructions for use and maintenance issued by the manufacturer of the stove (if such instructions are not provided with the stove),
- The documentation necessary to comply with the existing standards.

5.0. TECHNICAL CHARACTERISTICS

5.1 Accessories

Before the initial installation of the pellet stove, you should check whether all accessories are in place:

- Remote controller (if its provided)
- Control panel + screws for its mounting (in the reservoir for pellets)
- Power cord with cable
- Documentation (warranty, instruction manual, service)

Important: Read carefully the whole documentation and keep it attentively.

5.2 Assembling the control panel

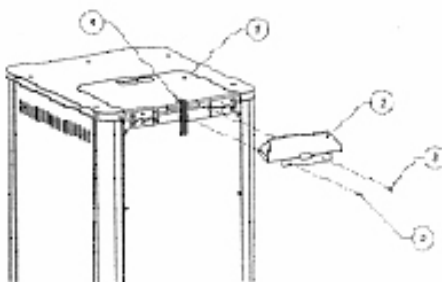

When you take the pellet stove out from its packaging, in the reservoir for pellets you will find the control panel (2) wrapped in a foil and M5 screws (3) mounted on back side of top , which are used for its assembling

(1). Take the M5 screws out and attach the panel to the cover.

Important: When connecting the panel, be careful not to cut the cable

5.3 Technical description

The **MODELS** is designed for heating residence or office spaces to be connected on system for central heating, at the same time contributing to the more pleasant ambience.

The boiler of the pellet stove is made of special metal sheet, as well as a supporting structure which is coated with high temperature paint. The burner and pellet transporter are made from cast iron.

The combustion chamber has a door with ceramic glass which is heat resistant at a temperature of up to

700°C. By this solution we wanted you to see the fire inside the chamber, at the same time avoiding contact with the dangerous sparkles and appearance of smoke. The door is hermetically closed.

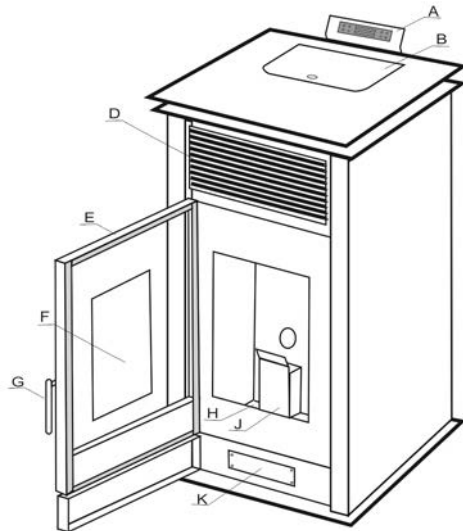

- A – CONTROL PANEL**
- B – PELLET TANK AND COVER**
- D – EXCHANGER OF HOT AIR WITH FAN**
- E – DOOR**
- F – CERAMIC GLASS**
- G – HANDLE**
- H – ASH COMPARTMENT**
- J – BURNER**
- K – OPENING COVER FOR GENERAL CLEANING**

5.4 Technical data and dimensions

Model of the pellet stove:		Fox IT 6	Fox IT 8	Fox IT 10	Fox IT 12
Height	mm	880	950	1100	1100
Width	mm	450	450	450	450
Depth	mm	480	480	480	480
Weight	kg	105	119	126	126
Diameter of air intake pipe	mm	80	80	80	80
Diameter of exhaust gas pipe	mm	80	80	80	80
Heating (*) volume	m ²	36-50	50-70	60-90	72-120
Nominal thermal power (P _{tn})	kW	6	8	10	12
Decreased thermal power (P _{tr})	kW	1.8	2.4	4.2	4.2
Max. consumption per hour	kg/h	1,5	1,95	2,3	2,7
Min. consumption per hour	kg/h	0,4	0,7	1,5	1,5
Reservoir capacity	kg	13	15	18	18
Autonomy at nominal thermal power	h	7.7	7.7	8	6.6
Autonomy at decreased thermal power	h	25	22	18	18
Utilization at nominal thermal power	%	92	92	92	92
Utilization at decreased thermal power	%	90	90	90	90
Nominal electrical power	W	340	340	340	340
Nominal voltage	V	230	230	230	230
Nominal frequency	Hz	50	50	50	50

The above table is made on the basis of tests conducted using wooden pellets with caloric power of 18220 KJ/kg (equal to 4350 Kcal/kg). Value depending on the place of installation.

The above values are indicative, not obligatory. The manufacturer retains his right to change the values in every moment in order to improve the performance of the product.

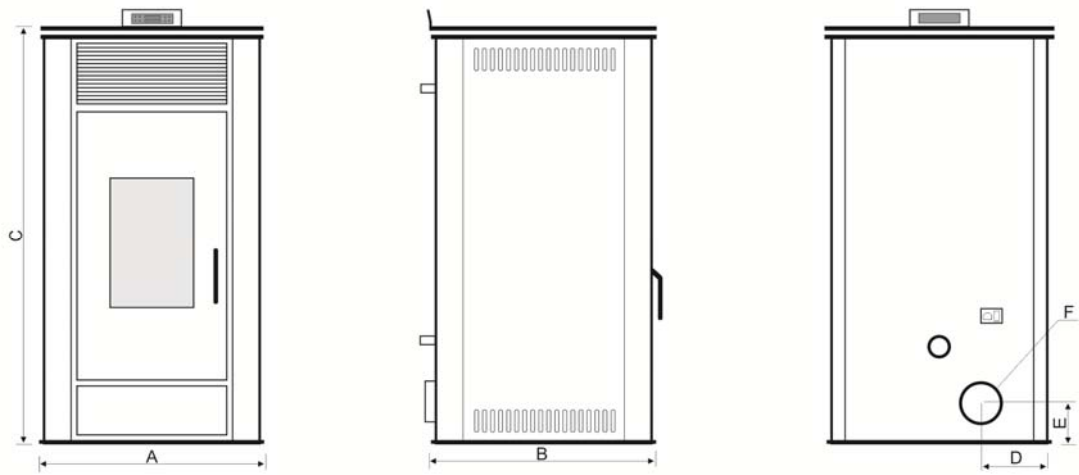

6.0 INSTALLATION SITE PREPARATION

6.1 General rules

Knowing that the proper assembly is very important, as well as the proper connection of the exhaust gas system and that the possible errors made during the assembly are not covered by the warranty of MANUFACTURER, our company advises the installation to be made after the following checks:

- Minimum volume of the space where the pellet stove is installed (avoid spaces smaller than 40m^3);
- Provide good air flow;
- Observe all the norms;
- Proper operation of the exhaust gas system;

You should also observe the following legal normative:

- Bans on installation
- The right to occupy a space

It is not allowed an installation of the pellet stove in bedrooms, toilets, and in spaces where already exists another heating body without sufficient air intake (pellet stove, gas stove etc.). It is not allowed the installation of the pellet stove in spaces containing explosive materials.

The installation of the pellet stove should be made in accordance to all practical knowledge. The space around the pellet stove should be made of stone, cement or other fireproof material. The pellet stove generates heat around the burner. Therefore, you should avoid contact of flammable materials with the burner (alcohol, paper, plastics ...)

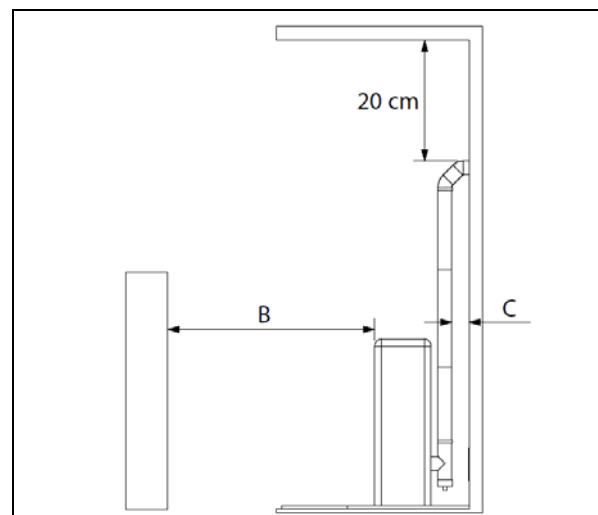
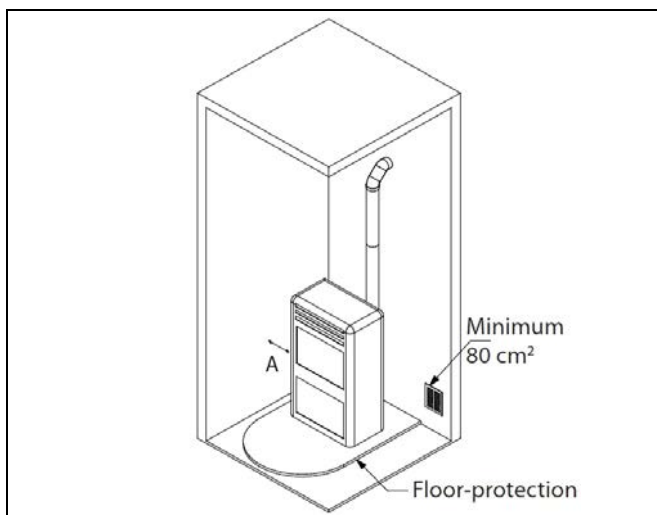

Minimal distance from the flammable materials is 200 mm except dimension explained on picture:

A = 200 mm , B = 200 mm , C = 100 mm

- If the floor is made of flammable material (parquet ...) it should be adequately isolated.
- The metal pipes intended for the gas exhaust should be at a distance of 1,5 m from flammable materials.
- We recommend that the pellet stove should be installed as closer as possible to the exhaust gas system, always having maximum 3+1T curves and maximum 3 m of horizontal flow with minimal elevation of 3-5%. As soon as the place of installation is defined, remove the cardboard and the other protective material and check whether the door is properly closed.

6.2 CONNECTION OF THE OUTER AIR PIPE

For proper operation and proper distribution of the temperature, the pellet stove should have sufficient air intake and to be placed on suitable place (a special hole for air intake can be made).

The hole for air intake should be 80 cm² minimum and there should not be any obstacles.

The air may be also taken from another room which is constantly ventilated and in which there is no other pellet stove or other system which needs an air intake. That room can not be a bedroom, toilet, another space where there is a danger of fire, such as a garage, basement, warehouse containing flammable materials.

If there is a pellet stove in the same room using gas from an open system or any other source of harmful gas, the air intake should be directly from outside.

AN EXAMPLE OF CONNECTION DIRECTLY FROM OUTSIDE

For the proper operation of the pellet stove a direct connection from outside is possible, using metal pipe of 43 mm (inside diameter) provided with silicon sealer. It is important that the front opening of the pipe is protected against wind, water or other, using a curve of 90° turned downwards.

Manufacturer does not bear any responsibility if the above indicated instructions are not observed. For proper placement of the air intake you should observe the following distances: 1,5 m underneath, 1,5 m horizontally, 0,3 m from above the doors, windows 2,0 m from the exhaust gas system.

6.3 EXHAUST GAS SYSTEM

It is always important to know that the chimney is important as the pellet stove.

The installation of the exhaust system on chimney should be performed by authorized persons. The authorized person should be guided by the following data for normal working of stove on reduced, maximal and nominal power, This data is optimal and used in laboratory when stove are tested.

Draft of the chimney	Pa	12
Mass of the combusted air	g/s	5.3

6.4 EXHAUST GASES AND INSTALLATION

The exhaust gas system operates as a result of depression which occurs in the combustion area. It is very important for the exhaust gas system, above marked as SIG, to be made of certified materials and:

- To be hermetically closed, meaning the system should be made of special pipes with adequate silicon sealer.
- To be able to operate under high pressure and under temperature range from 200-250°C (pipes with thickness not less than 1 mm is recommended).

If the pellet stove is connected to the existing system, the system should be checked by an authorized person. The system can not be installed indoors. Periodical cleaning of the exhaust gas system is recommended.

6.5 USABLE PIPES

The pipes used for the exhaust gases should be resistant, smooth from inside, made of metal and to have silicon sealer. The diameter of the pipes up to 3 m long should be 80 mm or 100 mm for pipes longer than 3 m or over 1200 m height above sea level.

The length is calculated along the whole horizontal and vertical length, counting each curve of 90° as 1 m of length.

ATTENTION

Do not connect the system to the existing system or to the aspiration system.

6.6 INSTALLATION SCHEMES (optional)

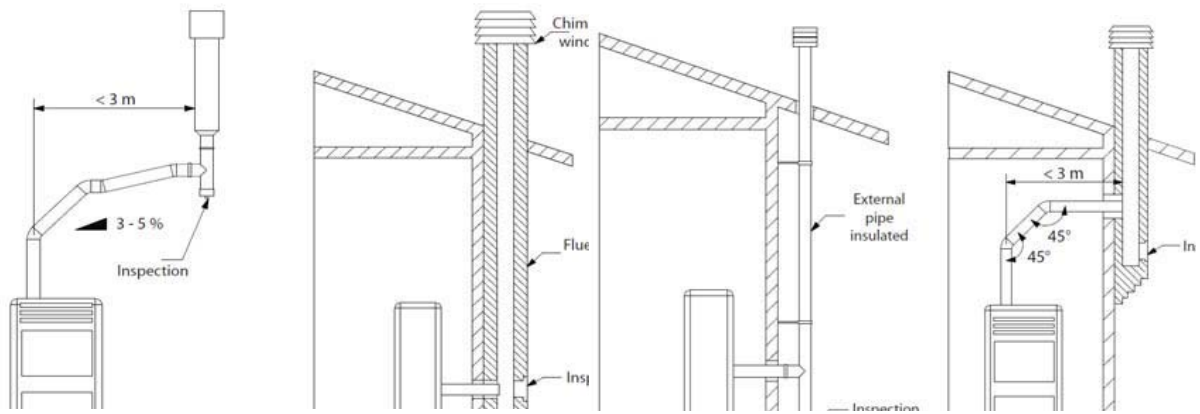

DANGER!

It is forbidden to install shut-off valves for the flow (draft) of air (flap valves that can prevent airflow or disable drafts).

ATTENTION !!!

If the ejection path of smoke creates such a bad draft, or a bad flow of air (many curves, improper completion of the ejection of smoke, constriction, etc.) discharge of smoke can be bad, or in a situation like this smoke discharging is not as good as it could be.

The smoke ejection system from the stove operates under negative pressure in the stove chamber and with mild pressure from the smoke drain pipe. It is very important that the smoke extraction system is hermetically closed (sealed). This requires the use of a smooth tube on the inside. First of all you must carefully study the plan and structure of the room when the smoke extraction pipe is set up through the walls and roof, so that the installation of pipes is performed properly in accordance with the standards of fire protection.

You should first ensure that the room where the stove is located has enough air for combustion. It is advisable to periodically perform check so as to ensure that the combustion air comes right up to the combustion chamber. The stove operates at 230 V ~ 50 Hz. Make sure that the electrical cord is not underneath the furnace, to be away from the stove, to be away from hot spots, and not to touch any sharp edges that it could interdict. If the stove is electrically overloaded, this can lead to shortening of the lifetime of the electronics of the stove.

Never turn off the power supply by pulling the plug when there is a burning flame in the stove. This could jeopardize the proper functioning of the stove.

6.7 REAR END OF THE EXHAUST GAS PIPE

The rear end of the exhaust gas pipe is intended for proper exhaust of the gases in the atmosphere, its protection against rain, snow or any other objects in order to guarantee excellent exhaust of the gases in windy conditions, as well.

The rear end of the exhaust gas pipe should meet the following requirements:

- The inner part should be the same as that of the pellet stove;
- The outer part should not be less than twice than the one of the pellet stove;
- The manufacture should protect the system against rain, snow and wind;
- Easy disassembling for cleaning purposes;
- Possibility for attractive finish which fits to the building.

The system should not have obstacles at a distance of less than 10 m, such as walls, trees. In such a case the system should end 1m above the obstacles, and in case of other systems, 2m from them, and in every case the system should be at least 1 above the roof.

	Dimension and position		
	Angle	Deference	Min H of chimney
β	A (m)	H (m)	
	15 °	< 1.85 > 1.85	0.5 m 1 m
30 °	< 1.50 > 1.50	0.5 m 1 m	
	45 °	< 1.30 > 1.30	0.5 m 1 m
60 °		< 1.20 > 1.20	0.5 m 1 m

	YES	NO

OPERATIONAL PROBLEMS DUE TO DEFECTS OF THE SYSTEM CAPACITY

Besides all influencing atmosphere agents, the wind is the most important agent for the system operation.

6.8 CONNECTION TO THE ELECTRICAL POWER SUPPLY

The product should be connected to the electrical power supply. Our pellet stoves are supplied with a medium temperature persistent cable. In case you need to replace the cable, call an authorized service agent. Before you connect to the electrical power supply, you should check the following:

- Whether the characteristics of the electrical power supply meet the requirements indicated on the plate
- Whether the connection is properly grounded
- The cable should not have temperature higher than 75°C.

In case of a direct connection to the electrical power supply, call an authorized person, an electrician. If you do not use the pellet stove for a longer time period, you should disconnect it from the electrical power supply. The connection should be easily accessible.

7.0 USAGE

7.1 SAFETY PRECAUTIONS

Taking into consideration that the pellet stove develops high temperature, the young and adult persons should be careful, and especially the children. It is forbidden to pour water or any other liquid which might cause temperature shock. Do not place flammable objects near the pellet stove.

7.2 IMPORTANT INSTRUCTIONS

THE FOLLOWING INSTRUCTIONS ARE REQUIRED FOR THE SAFETY OF PEOPLE, ANIMALS, AND PROPERTY.

We wish to inform the installer of the stove on some of the general guidelines which must be followed for proper installation and for proper stove mounting. These standards are required, but not completely. For further and more detailed information one needs to read the rest of this instructions manual.

- Plug the stove into an outlet that is grounded
- The switch on the rear of the stove is set to position 1
- Do not allow children or pets to be near the stove.
- Use pellets only, not other fuel.
- Notify all users about the potential risks and dangers and teach them how to handle the appliance.
- If the stove is placed on a wooden floor, then it is recommended to isolate the pedestal on which it stands.

The stove operates with a combustion chamber, which is in the negative pressure. **Therefore, make sure that the smoke is well thermally insulated.**

When the stove is turned on for the first time then, due to the stabilization process a small amount of paint (not harmful to health) that covers the stove vaporizes. It is therefore necessary to air the room so that it is cleared from the fumes.

7.3 WARNING SAFETY MEASURES FOR STAFF

MAINTENANCE

The contractors who work in maintenance, in addition to following all safety measures, must:

- Always use safety equipment and personal protective equipment,
- Turn off the power supply before they start working,
- Always use the appropriate tools,
- Before they begin any work on the stove they need to keep in mind that it should be cold and that the ashes should be cold as well. They need to make sure the handles are cold as well.
- **NEVER TURN THE STOVE ON** if there is just one of the safety devices that is defective, improperly set up or it does not work at all.
- Do not make modifications of any kind, for any reason, other than those permitted and explained by the manufacturer himself.
- Always use original spare parts. Never wait until the components wear out before you replace them. Replacing the worn parts or the components of the stove before they stop working contributes to the prevention of damage caused by accidents due to sudden failure, or breaking of the components, which can lead to serious consequences for people and/or property located around the stove.
- Clean the firebox before lighting the stove.
- Make sure there is no condensation. If condensation occurs it shows that there is water from the cooling smoke.

We recommend you find the possible causes to be able to establish a regular and correct operation of the stove.

7.4 WARNING SAFETY MEASURES FOR THE USER

The place where the stove is to be set up, called the mounting place, must be prepared by local, national, and European regulations.

The stove is a "heating machine" and while it is on **it has outer surfaces that are very hot or that achieve very high temperatures.**

This stove is designed to burn fuel from pressed wood mass (a pellet with a diameter of 6 mm with the length of 30 mm, with maximum moisture 8-9%).

It is therefore very important to pay attention to the following when the stove is on:

- Do not approach and touch the glass on the door, there is a BURNING HAZARD
- Do not approach and touch the smoke drain pipe, there is a BURNING HAZARD
- Do not do any cleanups
- Do not open the door because the stove is working properly only when it is sealed
- Do not throw away the ashes when the stove is ON

- Children and pets need to stand away from the stove
- FOLLOW ALL INSTRUCTIONS GIVEN IN THIS MANUAL

Likewise, the proper use of biofuel pellets means:

- Only use the fuel that meets the manufacturer's instructions,
- Always follow the maintenance plan for the stove,
- Clean the stove every day (only when the stove and the ash are cold),
- Do not use the stove in case of any defects or abnormalities, in the case of unusual noise and/or suspected faults,
- Do not spray water on the stove, even when fire fighting,
- **Do not turn off the stove by pulling the plug. Use the button on the board to turn off,**
- Do not tilt the stove, IT MAY BECOME UNSTABLE,
- Do not use the stove as a support or a holder. Never leave the tank lid open.
- Do not touch the dyed parts of the stove while it is ON,
- Do not use wood or coal as a fuel, **but only the pellet** with the following characteristics: diameter of 6-7 mm, maximum length 30 mm, maximum moisture content 8-9%,
- Do not use the stove to burn waste,
- Always perform all operations with maximum security measures.

7.5 SAFETY GUIDILINES FOR IGNITION AND CLEANING OF THE STOVE

- For turning the stove ON never use gasoline, kerosene or any other flammable liquid. Keep these types of fluid away from the stove while it is running,
- Never turn the stove ON if the glass is damaged. Do not strike the glass or the door so that they do not get damaged,
- While the stove is ON, do not open the door to clean the glass. Clean the glass only when the stove is cold, using a cotton cloth or paper towel and a glass cleaner,
- Make sure the stove is secure to prevent any movement,
- Make sure that the ash box is inserted and that it is fully closed, so that the doors are leaning properly on the box,
- Make sure the stove door is firmly closed while the stove is ON,
- Use a vacuum cleaner to pull the ashes from the stove only when the stove is completely cool,
- Never use abrasive cleaners for cleaning the surface of the stove.

IMPORTANT SAFETY INFORMATION

The manufacturer is always at your service to provide you with all the information you may need regarding the stove and instructions for assembly and installation in your geographical conditions. Properly connecting the stove, according to these instructions, is very important to prevent the danger of fire and any defects.

The stove works with a combustion suction pressure. **Therefore, make sure that the smoke is well thermally insulated.**

DANGER !

In case of fire in the smoke exhaust pipe take all the people and pets out of the room, unplug the power supply using the power switch in the house or remove the plug from the wall (plug must always be easily accessible and free of obstacles), and immediately call the fire department.

DANGER !

You cannot use conventional firewood.

DANGER !

Do not use the stove to burn waste.

8.0 FUELS

The only fuel which is allowed for use by the Manufacturer pellet stove is **the wooden pellets**.

In order to guarantee combustion without problem, the pellets should be kept in a dry place. We recommend usage of high quality pellets, compact and not powder-like. Inform yourself at your pellet vendor, which pellets are the best. Keep the pellets on a distance from the pellet stove, not less than 1,5 m (**see chapter 5.0**).

ATTENTION

The pellet stove is manufactured and tested only by using certified pellets. The manufacturer does not take any responsibility if you use non-certified pellets.

9.0 TECHNICAL SPECIFICATIONS

Electrical power supply 230V, 50/50Hz, maximum consumption 13/20 mA.

Inputs: Exhaust gas temperature probe, Temperature room probe, Differential pressure sensor (Hubo Control), Safety pellet temperature thermostat, Safety Pressure switch, Encoder for combustion fan, RS 232 connector.

Outputs: Combustion fan with encoder, heating fan, Igniters', Auger pellet engine, CN1 Keyboard connection

Room specifications:

Operative temperature – from 0 to 40°C , Storage temperature – from -10 to 50°C

Maximum relative humidity – 95%

INSTALLATION

All required cables and connectors are put into the pellet stove. The installation is quick and simple. Before each assembling of the system, an automatic test of the system is performed for its proper operation.

When you turn on the product for the first time, you should do the following:

When you are sure that the assembly is properly done, it is possible to start initial turning **ON** the pellet stove the setting might be made either through the control panel or the software.

For normal operation of the stove ALL PARAMETERS IS SAVE ON THE MOTHERBOARD.

10.0 ELECTRONIC COMPONENTS SCHEME

EasyTech.Full is a control system for pellet stoves available in the versions Air and Idro. It is characterised for:

- installing and use simplicity
- simple and direct user's functions
- reliable and flexible functioning software with well-established TiEmme elettronica technology
- advanced functions available for the builder to adapt to different stoves and installations

Product composition:

- control board with 4 fixing points, solid and sure
- extractable connectors
- exhaust temperature probe
- room temperature probe
- connection cable main board - control panel
- control panel with antistatic cover

Safety rules

Before working on the system make follow:

- the accident prevention and room prevention rules
- the national institute rules against the work accidents
- the legal safety rules
- these instructions are only for technical personnel only

Conformity declaration

Applied rules: EN 60730-1 50081-1 EN 60730-1 A1 50081-2

This manual is done with care and attention, but the information could be incomplete, not comprehensive or could have mistakes. For this reason the design, the information could be modified without advance notice according to the model.

TiEmme elettronica is not responsible for the incomplete or not correct information

ELECTRICAL CONNECTIONS

It is possible to use this control board matching or not an additional module.

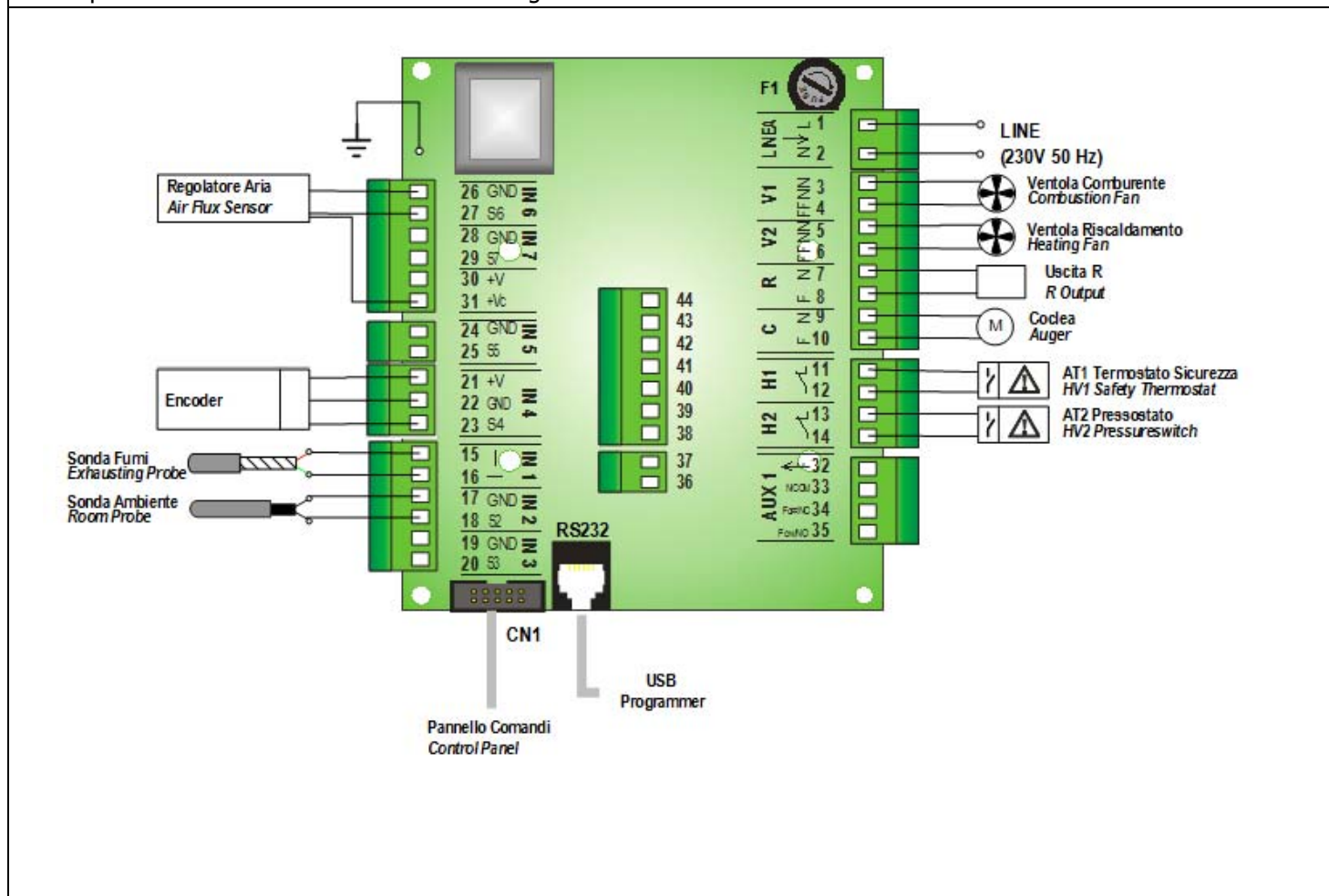

11.0 EXPLANATION OF THE ELECTRONIC CONTROL PANEL

Display LCD 100

The main frame shows:

time and date, chrono activation, combustion power, heating power, functioning state, error code, main temperature, main thermostat, led

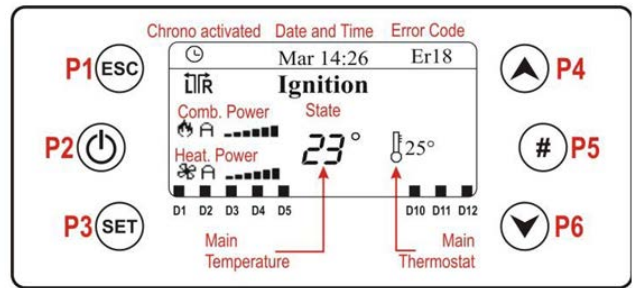

Button	Function		
P1	Exit Menu/Submenu		
P2	Ignition and extinguishing (push for 3 seconds), Reset errors (push for 3 seconds), Activation chrono		
P3	Enter in User Menu 1/submenu, Enter in User Menu 2 (push for 3 seconds), Save data		
P4	Enter in Visualizations Menu, Increase		
P5	Activation chrono time band		
P6	Enter in Visualizations Menu, Decrease		
Led	Function	Led	Function
L1	Auger ON	L8	External Chrono reached
L2	Heating Fan ON	L9	Lack of pellet
L3	R output ON	L10	Local Room Thermostat reached
L4	Ignition Resistance ON	L11	Remote Room Thermostat reached
L5	Aux2 output ON		

Display K 100

The main frame shows:

time and date, chrono activation, combustion power, heating power, functioning state, main temperature, main thermostat, led

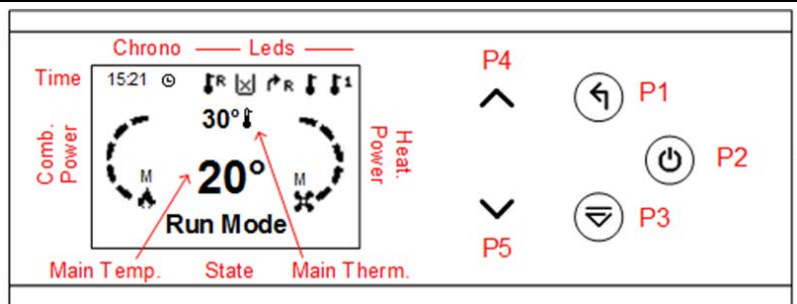

Button	Function		
P1	Exit Menu/Submenu		
P2	Ignition and extinguishing (push for 3 seconds), Reset errors (push for 3 seconds), Activation chrono		
P3	Enter in User Menu 1/submenu, Enter in User Menu 2 (push for 3 seconds), Save data		
P4	Enter in Visualizations Menu, Increase		
P5	Enter in Visualizations Menu, Decrease		
Led	Function	Led	Function
	External Chrono reached		Local Room Thermostat reached
	Lack of pellet		Remote Room Thermostat reached
	Direction of Air flow		

ALARMS

Description	System State	Code
Error Safety High Voltage 1: signalled also with the system Off	Block	Er01
Error Safety High Voltage 2: signalled only if the Combustion Fan is On	Block	Er02
Extinguishing for exhaust under temperature	Block	Er03
Extinguishing for exhaust over temperature	Block	Er05
Pellet Thermostat open (flame return from the brazier)	Block	Er06
Encoder fan error: no Encoder signal (in case of P25 =1 or 2)	Block	Er07
Encoder fan error: Combustion Fan regulation failed (in case of P25 =1 or 2)	Block	Er08
Day and time not correct due to prolonged absence of power supply	Block	Er11
Failed ignition	Block	Er12
Lack of voltage supply	Block	Er15

Communication RS485 error	Block	Er16
Air flow regulator error	Block	Er17
Run out of pellet	Block	Er18
Air Flow sensor damaged	Block	Er39
Minimum air flow in Check Up not reached	Block	Er41
Maximum air flow reached (F40)	Block	Er42
Open door error	Block	Er44
Auger Encoder error: no Encoder signal (if P81 =1 or 2)	Block	Er47
Auger Encoder error: auger speed regulation failed (if P81 =1 or 2)	Block	Er48
Module I/O I2C error	Block	Er52
Service error. It notifies that the planned hours of functioning (parameter T66) is reached. It is necessary to call for service.	Block	Service

MESSAGES		
	Description	Codice
	Probes fault in control during Check Up	Prob
	It notifies that the planned hours of functioning (parameter T67) is reached. It is necessary to clean the stove or boiler.	Clean
	Open door	Door
	The message appears if the system is turned off during Ignition (after Preload) by an external device: the system will stop only when it goes in Run Mode.	Block Ignition
	No communication between motherboard and keyboard	Link Error
	Periodic cleaning in progress	Cleaning On

Visualization		
	Display	Description
Exhaust T. [°C]	103	Exhaust temperature
Room T. [°C]	25	Local room temperature; it is visible only if A19 =1
Rem. Room T. [°C]	25	Remote room temperature; it is visible only if A18 =1 and P69 is greater than 0
Air Flux	750	Air flow; it is visible only if A24 is different from 5
Fan Speed [rpm]	1250	Exhaust fan speed; it is visible only if P25 is different from 0
Auger [°C]	1.2	Auger work time; it is visible only if P81 is equal to 0
Recipe [nr]	2	Combustion recipe set; it is visible only if P04 is greater than 1
Service [h]	500	Work time remaining before the system goes the message Service appears; it is visible only if T66 is greater than 0.
Cleaning [h]	450	Work time remaining before having to clean the stove; it is visible only if T67 is greater than 0.
Work time [h]	2985	Work time in Run Mode, Modulation and Safety
Ignitions [nr]	106	Number of ignition attempts
Product Code: 494-	0000	Product code

USER MENU 1	
Combustion Management	<p>Power In this menu is possible to modify the combustion power of the system. It can be set in modality automatic or manual. In the first case the system chooses the combustion power. In the second case the user selects the desired power. On the left side of the display are signalled the combustion modality (<i>A</i>=automatic combustion, <i>M</i>=manual combustion) and the working power of the system.</p> <p>Recipe Menu to select the combustion recipe. The maximum value is the number of recipes visible to the user (parameter P04). If P04=1 the Menu isn't visible.</p> <p>Auger Calibration It allows to modify the value set in firm of Auger's speed or On times. The values are in the range - 7 ÷ 7. The firm's value is 0. The menu is visible only if A64= 1.</p> <p>Fan Calibration It allows to modify the value set in firm of Combustion Fan's speed. The values are in the range - 7 ÷ 7. The firm's value is 0. The menu is visible only if A64= 1.</p>

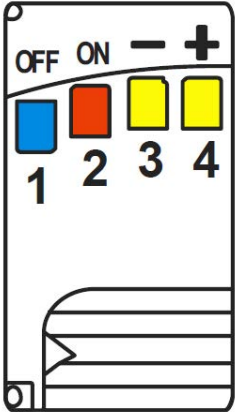
<p>Heating Management</p>	<p>Heating Power In this menu is possible to modify the heating power of the system. It can be set in modality automatic or manual. In the first case the system chooses the power, in the second case the user selects the desired power. On the left side of the display are signalled the heating modality (A=automatic, M=manual) and the working power. If A04=1 the Menu isn't visible.</p> <p>Canalization Power This Menu allows to manage the Canalization fan in automatic or manual mode (in this case it is possible to set the heating power). It is visible only if a heating plant with 2 Heating Fans is selected.</p> <p>Selector Menu This Menu allows to manage the Selector's position and change the heating air flow direction (Local= air flow in the local room, Remote=air flow in the remote room). It is visible only if P69=4, 5, 9, 10.</p> <p>Room Thermostat This Menu allows to modify the Local Room Thermostat's value. It is visible only if A19=1. If P69 is different from zero and the air flow is directed in the remote room is displayed the Th53 thermostat.</p> <p>Remote Room Thermostat This Menu allows to modify the Remote Room Thermostat's value. It is visible only if A18=1 and a heating plant that employ it is set.</p>											
<p>Remote Control</p> 	<p>This Menu allows to enable or disable the remote control.</p> <p><i>Buttons</i></p> <p>Button 1 activates extinguishing Button 2 activates ignition Button 3 or 4 decrease/increase the combustion power</p> <p><i>Learning Code</i></p> <p>On the Remote Controller:</p> <ul style="list-style-type: none"> - Open the battery case sliding the cover towards right - modify the configuration of the internal dip-switch and close <p>On the Control Board:</p> <ul style="list-style-type: none"> - switch off the power supply - switch on the power supply pressing at the same time one button on the remote control waiting about 5 seconds until an acoustic signal is emitted confirming the code learned 											
<p>Chrono</p>	<p>Modality, Chrono Program Used to program and activate the ignitions/extinguishing of the system.</p>											
<p>Manual Load</p>	<p>The procedure activates the pellet manual loading with activation in continue modality of the Auger engine. The loading is stopped automatically after 600 seconds. The system must be OFF for the function can be activated.</p>											
<p>Cleaning Reset</p>	<p>Menu to reset the 'System Maintenance 2' function. It is visible only if T67>0.</p>											
<p>Chrono</p>	<p>This Menu allows selecting the programming modalities and and the Ignition/Extinguishing time slots</p> <p>Modality It allows selecting the desired modality, or disable all set programming.</p> <ul style="list-style-type: none"> - enter modification mode through the key P3 or K3 - select the chosen modality (Daily, Weekly or Week end) - enable/disable chrono modality through the keys P2 or K2 <p>save the settings through the keys P3 or K3</p>	<table border="1" style="width: 100%; text-align: center;"> <tr><td colspan="2">Disable</td></tr> <tr><td colspan="2">Daily</td></tr> <tr><td colspan="2">Weekly</td></tr> <tr><td colspan="2">Week-End</td></tr> </table>	Disable		Daily		Weekly		Week-End			
Disable												
Daily												
Weekly												
Week-End												
<p>Programming The system includes three type of programming: Daily, Weekly, Week end. After selecting the desired kind of programming:</p> <ul style="list-style-type: none"> - select the programming time through the keys P4/P6 or K4/K5 - enter the adjustment modality (selected time will be flashing) through the keys P3 or K3 	<table border="1" style="width: 100%; text-align: center;"> <tr><td colspan="2">Monday</td></tr> <tr><td>ON</td><td>OFF</td></tr> <tr><td>09:30</td><td>11:15 ✓</td></tr> <tr><td>00:00</td><td>00:00</td></tr> <tr><td>00:00</td><td>00:00</td></tr> </table>		Monday		ON	OFF	09:30	11:15 ✓	00:00	00:00	00:00	00:00
Monday												
ON	OFF											
09:30	11:15 ✓											
00:00	00:00											
00:00	00:00											

- change the time via keys P4/P6 or K4/K5
- save the programming with the keys P3 or K3
- enable (a "V" is displayed) or disable the time slot (a "V" is not displayed") by pressing the keys P5 or K2

Daily
 Select the day of the week to program and set the ignition and extinguishing times.
 Programs around midnight

- Set the clock On of the previous day at the desired time: Ex. 20.30
- Set the clock of OFF of the previous day at: 23:59
- Set the clock On of the following day at 00:00
- Set the clock of OFF of the following day at the desired time: Ex. 6:30

-The system turns on at 20.30 on Tuesday and turns off at 6.30 on Wednesday

Weekly
 The programs are the same for all days of the week.

Week-end
 Choose between 'Monday-Friday' and 'Saturday-Sunday' and then set the switching on and off times.

Monday
 Tuesday
 Wednesday
 Thursday
 Friday

Mon-Fri
 Sat-Sun

USER MENU 2

The access to the menu is done by pressing **P3** and **P4** at the same time (keyboard CP110) or **K5** (keyboard CP120)

Keyboard Settings	Time and Date Used to set the day, month, year and current time.
	Language Menu to modify the language of the LCD board.
Keyboard Menu	Learn Menu It allows to manually update the menu; access is protected by a 4 digit password (<i>default password 0000</i>) and the procedure once started can't be interrupted. In case of a failed learning or menu changes, the learning procedure automatically starts.
	Set Contrast Menu used to regulate the display contrast.
	Set Minimum Light Menu used to regulate the lighting of the display when the command aren't used.
	Keyboard Address This menu is password-protected (<i>the password is 1810</i>); it allows to change the address of the RS485 node. In the RS485 bus it is not possible to have more nodes with the same address.
	Node List In this menu are shown: communication address of the board, typology of the board, firmware code and firmware version. Data are not modifiable. The typologies of board that can appear are: <i>MSTR</i> Master <i>INP</i> Input <i>KEYB</i> Keyboard <i>OUT</i> Output <i>CMPS</i> Composite <i>SENS</i> Sensor <i>COM</i> Communication
	Acoustic Alarm It allows to enable or disable the acoustic alarm of the keyboard.
System Menu	Menu to enter into technical menu. The access is protected by password (<i>default password: 0000</i>).

12.0 PELLETS

Pellets represent a valid alternative to the traditional energetic heating sources. First of all, they do not pollute the environment because they are bio compact, the CO emission is equal to zero, or equal to the quantity one tree absorbs to produce the same quantity of pellets. Pellets are totally natural products which entirely observe the living environment; they are produced from pure wood, throwing out the peel, without using colours.

No glue is used to put this product together. In essence, the compactness of the pellets is allowed by an ingredient which is found in the tree: LIGNITE.

Besides being an ecological fuel, completely burning out the wood, the pellets have technical advantages as well.

While the wood has an energetic power of 4,4 kW/kg (per 15% humidity, which means after storage of 18 months), the pellets have energetic power of 5,3 kW/kg.

The density of the pellets is 650 kg/m³, and the humidity is 8% of its weight and that is the reason why you do not need to store the pellets at all, but you can use them immediately. The pellets should meet one of the following standards:

- O-Norm M 7135
- DIN plus 51731
- UNI CEN/TS 14961

Regarding its products, **manufacturer** recommends that you should always use **pellets with 6 mm diameter**. Length of 24-36 mm.

12.1 STORAGE OF PELLETS

The pellets must be kept in a dry place that is not very cold. Cold and moist pellets (at the Temperature of around 50 C) reduces the thermal power of the fuel and requires additional cleaning of the stove.

THE PELLETS MUST NOT BE KEPT CLOSE TO THE STOVE. Keep them at least 2m away from the stove. Handle the pellets carefully and do not break them.

WARNING: If the fuel tank is filled with sawdust or small (decomposed) pellets, it can prevent the insertion of the pellets. Such pellets can lead to burning the electric motor that drives the mechanism for the insertion of pellets, or damage the gear that works in conjunction with this electric motor. If the bottom of the pellets reservoir, or, at the bottom of the gear unit when the tank is empty you see such a pellet, suck it up with a vacuum by swiping the tube through open grates of the pellets.

12.2 POURING THE PELLETS

INFORMATION AND ADVICES

Many of our clients ask how to recognize good pellets. Some of them say you should look at the colour, if it is dark, the pellets are of good quality, and on the contrary, if their colour is light, they are of poor quality. Some of them say that if the pellets smell bad, their quality is poor (because they are mouldy), some of them say to burn a small quantity of pellets and if they leave a lot of ash, etc...

Of course, it is about opinions related to different urban legends, which might have a scientific meaning, but, the main parameter for high quality pellets is the humidity: the less humidity, the better quality. The colour and the smell are of insignificant meaning. All kinds of pellets are produced from wood remainders and the colour and the smell are changeable depending on the wood used.

Mainly, it could be said that when selecting quality pellets, you should take into consideration the following:

- Determine if the product meets one of the following European standards, -O-Norm M 7135, DIN plus



51731, UNI CEN/TS 14961.

- Check the colour on the basis of the declared wood the pellets are made of
- Check if there are all necessary data on the packaging (energy power, place of origin etc.)
- Check if there is a lot of sawdust in the packaging, which would mean that the product is not compact, which results from a lot of humidity in the pellets. **The pellets should be smooth, compact and shiny.**
- Check the dimension of the pellets whether they match the dimensions declared on the packaging

IMPORTANT

The usage of poor quality pellets may damage the functioning of your pellet stove, which means that you will lose your warranty.

13.0 CLEANING AND MAINTENANCE

Regular cleaning of the pellet stove and the exhaust gas system is important for its efficient operation.

ATTENTION

When cleaning the pellet stove, it is important to cool down the pellet stove and the exhaust gas system pipes. Do not use combustible cleaners.

13.1 CLEANING AND MAINTENANCE OF THE EXHAUST PIPE

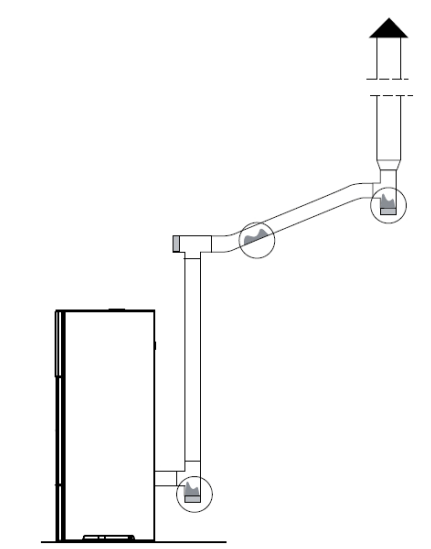

The tar is a liquid which appears when the combustion is poor as a consequence of the low temperature in the pipe. In case of occurrence of tar, it is recommended that the pipe should be isolated well. Deposition of this liquid may cause a fire. So, the exhaust gas system should be checked and cleaned at least once during the heating season.

ATTENTION

A clean system of exhaust gases is the guarantee for both the facility and the proper operation of this products. It is important to clean the system on a regular basis. The exhaust gas system should be checked and cleaned when the pellet stove is turned on for the first time.

13.2 CLEANING AND MAINTENANCE OF THE PELLET STOVE

	Every start	Weekly	After 2000 kg	1 Year (General)
Burning pot	X*	X		
Ash bin		X		
Glass		X		
Ignition socket		X		
Flue gas ash bin			X	X
Heat exchanger			X	X
Fans				X

* - Depend of the quality of pellet burning pot (J) must be in good condition for new start. User can clean weekly or to check daily to decide cleaning after several days

The cleaning and the maintenance of the pellet stove are important for its proper operation. The

maintenance of the pellet stove should be performed on time, and the general cleaning is recommended to be performed after each use of 2000 kg pellets, and at least once a year.

13.3 PERIODICAL CLEANING (Weekly)

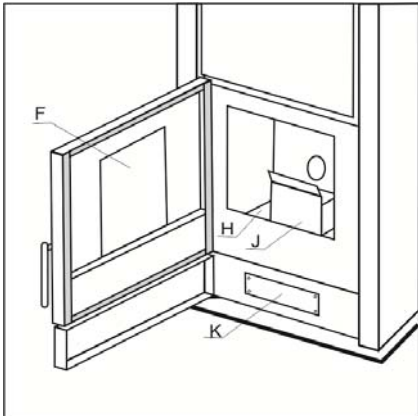

For proper work of the stove user must to perform periodically cleaning. The stove can operate and must to be cooled down.

- Cleaning of burning pot (**J**) to be made with extraction of the pot outside of the stove and cleaning complete pot with attention all hole for air to be open.
- Cleaning of ash bin (**H**) to be made with using of vacuum cleaner after extraction of the burning pot from stove.
- Cleaning of the glass (**F**) can be using a damp cloth or moistened paper passed try the ash. Detergent suitable for kitchen oven can also be used. Be careful to not wet the door gasket as this may be damaged.
- Cleaning of ignition socket can be performing with extracted burning put using vacuum cleaner.

13.4 GENERAL CLEANING (after 2000 kg and one year of use)

The cleaning and the maintenance of the pellet stove are important for its proper operation. The maintenance of the pellet stove should be performed on time, and the general cleaning is recommended to be performed after each use of 2000 kg pellets, and at least once a year.

- Cleaning of ash bin (**K**) is simple and can be performed even early from this plan. Open with screwdriver four bolts on the cover plate. Take out the plate and use vacuum cleaner to clean inside area of ash bin till the exhaust fan entrance. After finish of cleaning close back cover plate with attention to not damage rope and with screwdriver back bolts on same place.
- Cleaning of heat exchanger are with using vacuum cleaner and clean up from the burning pot.

A list of the most important inspections which should the service centre make when it performs a general inspection of the pellet stove:

- Cleaning of the aspirator and the fan;
- Cleaning of all unreachable places of the burner;
- Inspection of all bars;
- Inspection of the ignition system and the system for pouring the pellets;
- Inspection and possible replacement of the door rope;
- Disassembling and cleaning of the T junction of the exhaust gas system;
- Inspection of all electronic parameters;
- Issue of a certificate for the completed inspection.

ATTENTION

Do not clean the system until completely cooled down.

- OTHER SURFACE

Use soft cloth and neutral detergents.

- DOOR ROPE

The rope guarantees air tightness of the door and proper operation of the pellet stove. It is good to check the rope and if damaged, to replace it. This operation should be performed by an authorized person.

- PELLET RESERVOIR

It is recommended to periodically clean the reservoir (at least once a month); firstly you should empty it and then clean it using a vacuum cleaner.

- FRESH AIR INTAKE SYSTEM

At the beginning of the heating season you should check the fresh air system, whether there is any obstacle in it.

EXHAUST GAS SYSTEM

At the beginning of the heating season you should clean the exhaust gas system.

If the electrical cable is damaged, replace it.

IMPORTANT: For cleaning the colour surfaces, do not use cleansers containing acid.

14.0 POST-SALE SUPPORT

When you buy the stove, please contact the nearest authorized service.

SAFETY MEASURES

The stove is equipped with the following safety devices:

- VACUM PRESSURE SENSOR

Checks the under pressure in the burning chamber and send data to electronic to be able to control all the time same pressure and stabile burning parameters'. If for some reason the electronic board can make control according data from this sensor (open door, high wind, some failure) the board send signals and stops stove with message of error

- FLUE GASES TEMPERATURE SENSOR

Checks the temperature of flue gases controlling over burning temperature and send stove to modulation mode for high temperature, allow stove to be turned ON or stop the ignition if the flue gas temperature drops down below the programmed value.

- CONTACT THERMOSTAT ON THE AUGER (Pellet transporter)

When the temperature goes over the set safety value for reason of back fire the stove will load in pot the burned pellet and start procedure for turning off.

- AIR TEMPERATURE SENSOR

If the air temperature sensor rich the stop-temperature (40 ° C) the sensor triggers the stove to do a series of cooling cycles or turns the stove off automatically.

- ELECTRIC SAFETY

The stove is protected from high current disturbances using standard fuses that are located in the main switch on the back side of the stove and on the control panel - the motherboard.

- FLUE GASES FAN

If the fan stops, the motherboard immediately blocks the supply of pellets and an alarm signal will show.

- GEAR MOTOR

When the gear motor stops working, the stove keeps on working until the flame, due to the lack of oxygen, goes out and until the stove reaches the minimal cooling level.

- INTERRUPTION OF ELECTRICITY

If there is a interruption of electricity depend of the temperature and phase of burning of the stove automatically decide possibility to continue or starts to cool down (shut down stove).

- NO IGNITION

If for some reason there is no flame when you turn the stove on the stove goes into an alarming state.

15.0 FAILURES - CAUSES – SOLUTIONS

IMPORTANT !!! After any error message user must to reset error with long pressure on button ON/OFF

ALARM	PROBLEMS	POSSIBLE CAUSES	SOLUTIONS
Er01	Error Safety High Voltage 1: signalled also with the system Off	1. Safety device are ON	1. Stove will auto switch OFF 2. Reset error with long pressure on button ON/OFF 3. Try to start stove again 4. If error appear call service
Er02	Error Safety High Voltage 2: signalled only if the Combustion Fan is On	1. Safety device are ON	1. Stove will auto switch OFF 2. Reset error with long pressure on button ON/OFF 3. Try to start stove again 4. If error appear call service
Er03	Extinguishing for exhaust under temperature	1. Pellet tank empty 2. Transporter stack and is blocked 3. To much ash in burning chamber 4. Burning pot are blocked (not clean)	1. Load pellet in tank 2. Unload all pellet from tank and clean transporter 3. Clean ash and burning pot. 4. Reset error with long pressure on button ON/OFF 5. If error appear call service
Er05	Extinguishing for exhaust over temperature	1. Room temperature probe adjusted on to high temperature 2. Stove not cleaned periodically and exhaust fan are dirty	1. Check room temperature adjustment and make correction 2. Clean stove following instruction 3. Reset error with long pressure on button ON/OFF 4. If error appear call service
Er06	Pellet Thermostat open (flame return from the brazier)	1. Pellet start to burn back in the tank 2. Stove is using on the place biggest that capacity and run without stop many hours.	1. Stove will auto switch OFF 2. Check capacity of the stove 3. Reset error with long pressure on button ON/OFF 4. Try to start stove again 5. If error appear call service
Er07	Encoder fan error: no Encoder signal	1. Exhaust fan encoder do not give data to the electronic board	1. Stove will auto switch OFF 2. Reset error with long pressure on button ON/OFF 3. Try to start stove again if the encoder is fail the stove will start using voltage for controlling data. 4. Call service if alarm appear again and even the stove is run (the system have solution to work till service come to check)
Er08	Encoder fan error: Combustion Fan regulation failed	1. Exhaust fan encoder do not give data to the electronic board 2. The exhaust fan is stacked or failed 3. The system is not clean periodically	1. Stove will auto switch OFF 2. Reset error with long pressure on button ON/OFF 3. Clean stove following instruction 4. Try to start stove again. 5. If error appear call service
Er11	Day and time not correct due to prolonged absence of power supply	1. The stove are switched off from power very long time. 2. The battery on main board are defective	1. Power ON stove and adjust date and time 2. If error appear call service to change main board battery

Er12	Failed ignition	<ol style="list-style-type: none"> 1. To much ash in burning chamber 2. Burning pot are blocked (not clean) 3. The pellet is wet 4. Pellet tank empty 5. Transporter stack and is blocked 	<ol style="list-style-type: none"> 1. Clean ash and burning pot. 2. Load pellet in tank 3. Unload all pellet from tank and clean transporter 4. Check the pellet moisture 5. Reset error with long pressure on button ON/OFF 6. If error appear call service
Er15	Lack of voltage supply	<ol style="list-style-type: none"> 1. The voltage are lack for some reason 	<ol style="list-style-type: none"> 1. If there is happen lost of power from supply then reset stove and start again, if not then 2. Check the stove cable 2. Check the power connection 3. Check the main fuse in house 4. If error appear call service
Er17	Air flow regulator error	<ol style="list-style-type: none"> 1. Air flow sensor do not send data to main board or connection cable are fail. 	<ol style="list-style-type: none"> 1. Stove will auto switch OFF 2. Reset error with long pressure on button ON/OFF 3. Try to start stove again if the air flow sensor is fail the stove will start using fixed parameters’. 4. Call service if alarm appear again and even the stove is run (the system have solution to work till service come to check)
Er18	Run out of pellet	<ol style="list-style-type: none"> 1. No pellet in tank 	<ol style="list-style-type: none"> 1. Stove will auto switch OFF 2. Load pellet in tank 3. Reset error with long pressure on button ON/OFF 4. If error appear call service
Er39	Air Flow sensor damaged	<ol style="list-style-type: none"> 1. Air flow sensor are fail 	<ol style="list-style-type: none"> 1. Stove will auto switch OFF 2. Reset error with long pressure on button ON/OFF 3. Try to start stove again if the air flow sensor is fail the stove will start using fixed parameters’. 4. Call service if alarm appear again and even the stove is run (the system have solution to work till service come to check)
Er41	Minimum air flow in Check Up not reached	<ol style="list-style-type: none"> 1. The rope on door is damaged 2. Stove is not cleaned periodically 3. Air intake pipe are blocked 	<ol style="list-style-type: none"> 1. Check the door and rope 2. Clean stove following instruction 3. Check air intake pipe and complete intake system 4. Reset error with long pressure on button ON/OFF 5. If error appear call service
Er42	Maximum air flow reached	<ol style="list-style-type: none"> 1. The exhaust fan are damaged 2. Stove is not cleaned periodically 3. The exhaust system pipe are blocked 	<ol style="list-style-type: none"> 1. Check and change fan 2. Clean stove following instruction 3. Check exhaust pipe and complete exhaust system 4. Reset error with long pressure on button ON/OFF 5. If error appear call service
Er44	Open door error	<ol style="list-style-type: none"> 1. Door is open 	<ol style="list-style-type: none"> 1. Check the door if open close 2. Check the rope on door 4. Reset error with long pressure on button ON/OFF 5. If error appear call service

Er47	Auger Encoder error: no Encoder signal	1. Auger encoder do not give data to the electronic board	1. Stove will auto switch OFF 2. Reset error with long pressure on button ON/OFF 3. Try to start stove again if the encoder is fail the stove will start using seconds for controlling data. 4. Call service if alarm appear again and even the stove is run (the system have solution to work till service come to check)
Er48	Auger Encoder error: auger speed regulation failed	1. Auger encoder do not give data to the electronic board 2. The auger motor is stacked or failed	1. Stove will auto switch OFF 2. Reset error with long pressure on button ON/OFF 3. Check the auger motor 4. Try to start stove again. 5. If error appear call service
Er52	Module I/O I2C error	1. The flat cable connection between main board and control panel are break 2. The control panel are fail	1. Stove will auto switch OFF 2. Reset error with long pressure on button ON/OFF 3. Check the flat cable and change if fail 4. Try to start stove again. 5. If error appear call service
SERU	Service error.	1. It notifies that the planned hour of functioning is reached. It is necessary to call for service.	1. Call service

INFORMATION ON DISPOSING (THROWING AWAY) AND DISMANTLING (PULLING APART) OF THE STOVE

Dismantling and throwing away, or disposing of an old used stove is the sole responsibility of the owner. The owner of the stove must abide by the regulations in his/her country related to the safety and environment protection. Dismantling and disposing of the stove may be left to a third party to do if the third party is a company authorized to collect and dispose of such materials.

NOTICE: *In all cases you must abide by the applicable regulations of the country where the stove is installed regarding disposal of such materials (things) and, if necessary, report the disposal of such items.*

ATTENTION

Dismantling the stove must be done only when the chamber of the stove is not working and when the stove is unplugged from power (no power supply).

- *pull out all electric parts,*
- *throw away the batteries and electronic cards of the remote control in the proper garbage cans in accordance with the standards.*
- *separate the batteries you are keeping from the electric cards,*
- *dismantle the stove with the help from an authorized company*

ATTENTION

Disposing of the stove in public places poses a serious risk for people and animals. In such cases it is always the responsibility of the owner if a person or an animal gets hurt.

When the stove is dismantled, this manual and all other documents related to the stove must be destroyed.

THE DURATION OF GUARANTEED SERVICE

By this we mean the time in which we guarantee service, accessories, and spare parts, starting from the date of purchase of the appliances.

The time of the guaranteed service is in accordance with the legislation.

In case of a change of the model and design of the appliance, the deadline for replacing the parts for which the design has been changed is within the legal deadline.

After this period the affected parts are provided in the new designs.

16.0 WARRANTY TERMS AND CONDITIONS

Product warranty is valid within the legally defined deadline.

The warranty does not apply to the glass or to the physical damage caused after purchase.

THE MANUFACTURER RESERVES ALL RIGHTS TO CHANGES.

The appliance will, within the warranty period, only function correctly when used in accordance with the instructions for connection and use.

The warranty ceases to be valid if it is determined that:

- Connecting the product or repair was performed by unauthorized persons, or if they built in counterfeit parts,
- If the appliance is not properly used in accordance with this instructions manual,
- If during use there was mechanical damage to the appliance,
- If the fault repair was done by unauthorized persons,
- If the appliance was used for commercial purposes,
- If the damage occurred during transportation after selling the appliance,
- If the failure was due to improper installation, improper maintenance, or mechanical damage caused by the customer,
- If the malfunction was due to too much or too low voltage as well as due to force majeure.

Malfunctions of the appliance can be removed outside the warranty period with original spare parts that we also give a warranty for under the same terms and conditions.

This warranty does not exclude or affect the rights of consumers in connection with the goods in accordance with legal provisions. If the delivered product does not match the contract, the consumer has the right to require the seller to fix this by repairing or replacing the product in accordance with legislation that is in effect.

IMPORTANT NOTES

1. If the service repairing lasts for more than 15 days we extend the warranty period for time of how long the repairing lasts. If the service repairing lasts for more than 45 days we will replace the product with a new one.

1. PRODUCT _____
2. DATE OF PRODUCTION _____
3. SEAL AND SIGNATURE OF THE SALESPERSON _____
4. SERIAL NUMBER OF PRODUCT _____