



WOOD PELLET BOILER Waterland S 40 INSTALLATION AND OPERATION MANUAL



Contents:

1. General Instructions, page 2
2. Description of Design and Structure, page 3
3. Burner's Basic Specifications and Capacity, page 4
4. Basic Technical Specifications and Requirements to the Burner, page 6
5. Installation of Burner and Controller-to-Boiler Installation, page 6
6. Burner Description and Operation Manual, page 8
7. Basic Technical Specifications and Parameters of EMC 1, page 14
8. Electrical Wiring Drawing, page 17
9. Troubleshooting, page 18
10. Cleaning Instructions, page 22
11. Pellet Hopper Installation, page 23
12. Warranty, page 24

Dear Users,

Thank you for purchasing our product! Waterland S40 boiler with a wood pellet burner Waterland IVG bioenergy S40 is a quality tested product with intuitive menu, easy to operate and maintain. We believe to have provided you with a warmth and comfort solution.

Caution!

For your safety and accident-free operation, please, read these instructions carefully, prior commencing or attempting installation and operation of the boiler.

1. General Instructions:

The "Waterland" boiler is manufactured in compliance with the requirements of Regulation No. 29 on "Structure and Operation Safety of Low Pressure Steam and Water Boilers". The "Waterland" boiler is designed to heat up the heat medium (water) of the heating system using calorific energy, achieved through wood pellet burning. The boiler is appropriate for use in central heating systems with heat medium temperature not exceeding 90°C, at a maximum working pressure of water up to 0,4 MPa. The boiler is provided with a full automatic operation mode option.

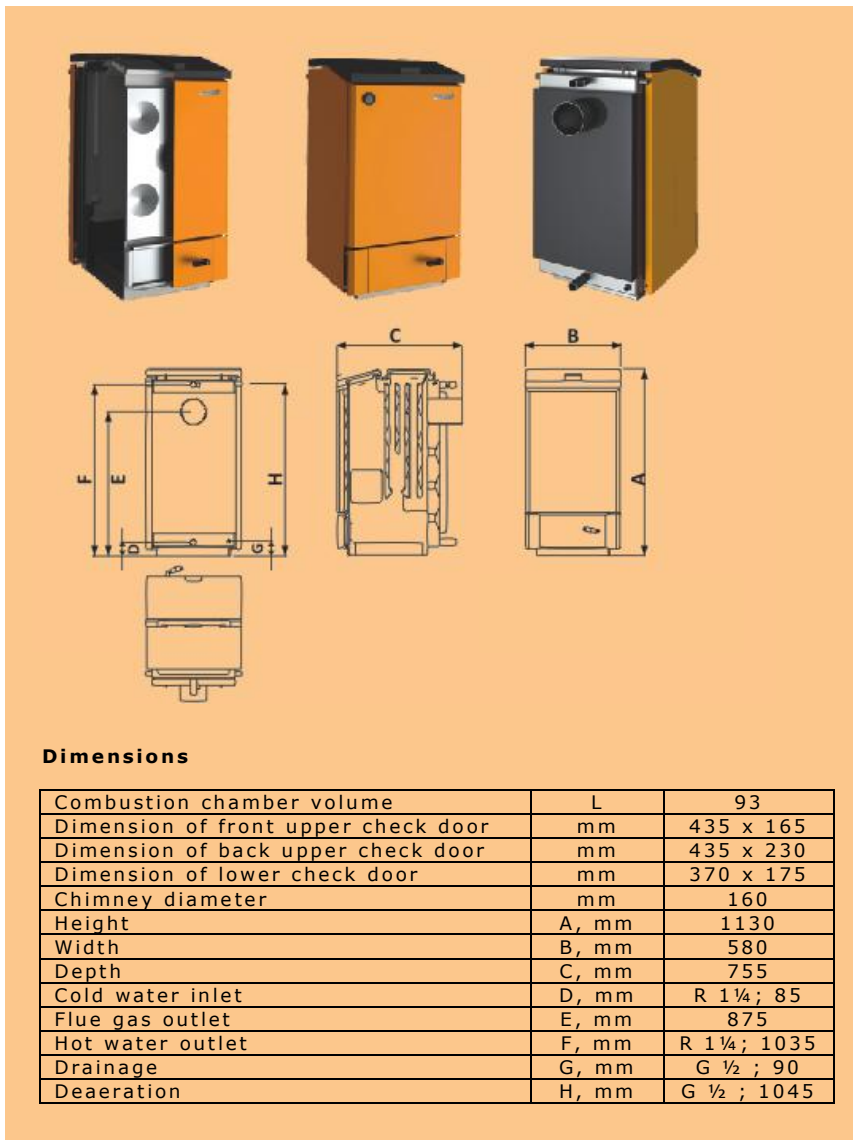

Technical data for boiler Waterland S40		
➤ Rated power	kW	6 to 25
➤ Maximum power	kW	32
➤ Maximum operating pressure	bar	2.5
➤ Weight	kg	260
➤ Insulation	40 mm mineral wool	
➤ Flue gas temperature	150°C	
➤ Water jacket volume	L	68
➤ Operating temperature	60-90°C	

Technical data for burner Waterland S40	
➤ Noise level	Max 60 dB
➤ Unused pellets dimension	6 – 80mm
➤ Display	LCD 128x 64
➤ Power supply	220-240 V AC
➤ Power consumption	5 – 400 W
➤ Clock / week calendar	Not dependent on the circuit
➤ Memory	Power independent
➤ Battery (clock)	Keeps current time of EMC for a 10-years' period
➤ Ambient temperature operation	5°C – 45°C
➤ Sensors	Temperature sensor, light sensor and a thermostat
➤ Ambient humidity at 30°C	95%

2. Description of Design and Structure

The body of the boiler has been completely made of steel. The boiler combustion chamber has been made of special sheet iron Grade "P", used in items operating under high working temperature, and 4 mm thick. The boiler's water jacket is of 3 mm thickness, whereas deformations in certain locations of its structural elements guarantee its strength. The vertical heat-exchanger ensures three-fold change of exhaust gas direction and appropriate heat-exchanging. The wood pellet burner can be mounted on either side of the boiler. The casing insulating mineral wool thickness is 40 mm. The casing is of 1 mm thickness with powder paint finishing. The boiler has been provided with wide manholes and an ash grate.

The duct to the chimney shall not exceed one meter in length and shall have a capped opening, allowing cleaning. The chimney exhausting power shall be constant, at least 5 Pa, and a stabilizer thrust shall be installed at all times. Provided exhaust gases condense in the chimney (wet soot), a stabilizer thrust shall be mounted to the chimney, or, alternatively, the damper valve (located internally at the rear of the boiler) shall be open as wide as possible to increase the temperature of exhaust gases and smoke. The boiler shall be isolated through a bypass so that the return water temperature is always above 45°C.

Components of the Boiler (Fig. 1):

I. Controller - provides full automatic control on the burner, having the following outlets (on either side):

- Main power cable - supplying 220-230V AC power;
- Main power cable to the water pump (electrical drive) - supplying power the water pump (electrical drive) of the heating system;
- Power supply to the auger - supplying electricity and auger control;
- Power supply (connector) cable to the burner - supplying electricity and control of burner;

- Temperature sensor - reading the boiler temperature (shall be firmly secured at the specified location!!!)

II. Pellet auger - assures pellet transportation, consisting of the following components:

- spring conveyor tube - transports pellets along the tube;
- auger head - housing the reducer-motor, as well as all electrical auger connections;
- pliable pellet duct - assures pellet transportation from the auger tube to the burner;

III. Burner - assures complete burning of pellets, consisting of the following components:

- Combustion chamber - allowing for maximum combustion and burning;
- Grate - mounted in the combustion chamber of the burner, providing pellet burning layer;
- Heating spark plugs - assure ignition of the pellet burning material;
- Drop - directs the pellets toward the grate;
- Air box - assures air flow distribution;
- Metal pellet duct - assures pellet material transportation to the grate;
- Air blower - supercharges the required amount of air;
- Photo sensor - monitors the flame intensity;
- Thermostat - assures accident protection from the so called reverse combustion;

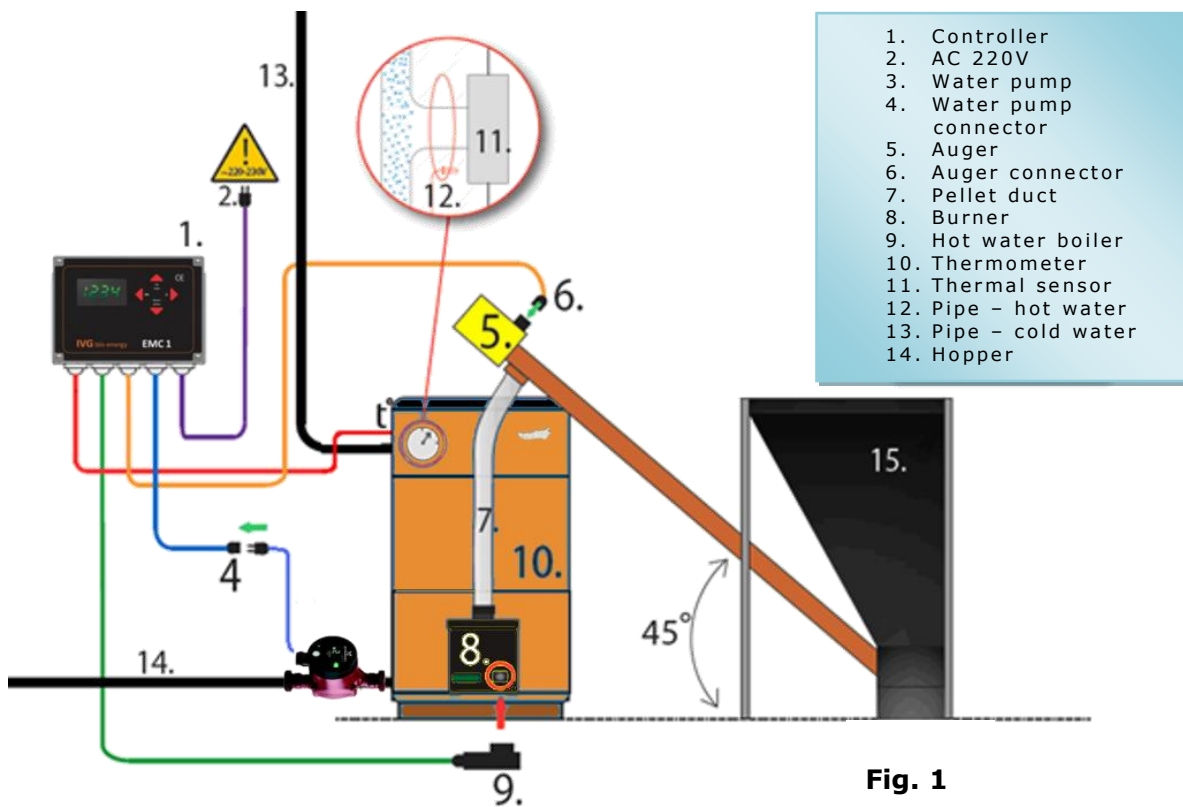

Fig. 1

3. Burner's Basic Specifications and Capacity

Waterland IVG bioenergy S40 is a modulating burner, intended for integration with water heating boilers designed for home and public premises heating. The burner operates with wood pellets.

- ✓ Burner control is provided through an EMC 1 controller, allowing full automatic ignition and burning process automation, as well as precise control on the ash content and air, thus increasing the coefficient of efficiency of the burner and saving on pellet fuel.

- ✓ The controller menu supports Bulgarian and English language (Greek can be installed as an option);
- ✓ Smooth regulation of burner power - the burner power is regulated to meet the required power, depending on the instantaneous consumption and the heating system available. This method of burner power control is used by the modulating burners, thus considerably decreasing the pellet fuel consumption (up to 30% compared to the on-off type of burners).
- ✓ Upon reaching the temperature preset, the burner automatically switches into a modulation mode.
- ✓ In case of no heat consumption for a longer period, within the interval $t^{\circ} C$ (preset) to $t^{\circ} C (+)$ hysteresis, the burner works at 10% of the capacity.
- ✓ Upon reaching $t^{\circ} C$ (preset) (+) hysteresis, the burner goes into "pause" (standby mode), during which no fuel is fed.
- ✓ Automatic restart is carried out upon fall of temperature down to the preset $t^{\circ} C (-)$ $1/2$ hysteresis.
- ✓ Intelligent control system upon cut-out of electricity during operation - the control ensures automatic ignition upon restoration of power.
- ✓ Program selection of the maximum power for each boiler selected by the user, for 16 kW, 24 kW and 32 kW - MANUAL ADJUSTMENT OPTION TO ANY OTHER POWER REQUIRED WITHIN THE RANGE OF 6 - 40 kW (no mechanical fine-tuning required).
- ✓ Mounting and dismounting are easy to carry out.
- ✓ Exceptionally easy to repair and maintain (due to the modules).
- ✓ Fast ignition at low electricity power consumption (350 W), carried out by two electrical heaters of 150 W (fail-safe ignition) and two-speed blowing.
- ✓ Exceptional gas dynamics, which creates sub-atmospheric pressure in the pellet duct - prevents reverse combustion even upon unpressurized pellet duct.
- ✓ Pellets are fed from the metal pellet duct along the drop to the combustion chamber creating an air cushion, optimizing the pellet feeding process.
- ✓ Combustion chamber - hyperventilated, providing conditions for complete fuel burning and meeting the criteria of the highest emission class 5 for pellet burners.
- ✓ Gas-dynamic cooling of combustion chamber walls extends the burner life-cycle.
- ✓ Gas-dynamic self-cleaning during operation - option for presetting cleaning and cleaning intervals schedules.
- ✓ Self-cleaning on stop and first-time start.
- ✓ Automatic boiler circulating pump control over $40^{\circ}C$ provides an option for presetting switch-on temperature.
- ✓ Automatic switch-off upon congestion, with notification displayed on the screen.
- ✓ Automatic switch-off is also provided upon running out of fuel, with notification displayed on the screen.
- ✓ Emergency stop in case of damaged or cut off supply cable of thermo-sensor - the burner cannot operate: either stops or doesn't start.
- ✓ Back-fire thermo-protection, achieved through a thermostat installed in the base of the metal pellet duct. Upon activation of the back-fire thermo-protection, the burner switches into emergency mode and stops operating.
- ✓ In case a foreign body stacks into the auger, it stops turning without causing damage to the motor or the control, complying with the pellet burner standard requirements.
- ✓ Real time clock - independent of the electricity grid power supply.
- ✓ The burner has been provided with a weekly scheduler.
- ✓ An option has been provided for external or built-in weekly scheduler control (programmable thermostats) and/or "start and stop" control via a mobile phone (an option). In case of eventual boiler overheating above $95^{\circ} C$, the burner switches to emergency mode, whereof an indication is displayed on the screen - starting the burner in this mode is not possible.

The burner uses pellets Class "A" (real) ϕ 6-8 mm;

4. Basic technical specifications and requirements to the boiler to which a burner shall be installed:

- Distance between the head end and the cooling boiler surface shall be 150 mm;
- The burner shall be mounted to a boiler with the following dimensions (or boiler to be ordered shall be with the following dimensions):
 - height - 105 mm;
 - width - 180 mm;
 - minimum depth from burner flange to cooling boiler surface - 310 mm;
- Recommended minimum chimney exhausting power: 15 Pa;
- Fresh air access to the burner: $\sim 90 \text{ m}^3/\text{h}$;

5. Installation of Burner and Controller-to-Boiler Installation

THE BURNER SHALL BE INSTALLED BY AN AUTHORIZED SERVICE TEAM! CHIMNEY EXHAUST POWER SHOULD BE AT LEAST 15 Pa, SUSTAINABLE! IT IS RECOMMENDED THAT A THRUST STABILIZER BE INSTALLED!

1. The EMC 1 controller (see Fig. 1. - 1) shall be installed at an appropriate location, allowing direct access by the user. Upon its installation into the board or wall-mounting, the location shall be selected so that it is not affected by heat or moisture to keep its components safe. Mechanical mounting of EMC 1 shall be carried out using metal bed plates, included in the burner set.

2. It is the boiler that shall be first installed and leveled. The burner is mounted to the boiler either to its left or right hand side, depending on the heating installation designed. The boiler design allows burner mounting on either side.

The mounting inclinations of the burner and the auger shall be obligatorily complied with, as shown in the figure. This would guarantee its correct and economic operation. Burner mounting inclination has been factory-preset, through the boiler flange.

CAUTION! Non-compliance with the above requirements would result in either excess fuel consumption or burner stacking (it stops operating and switches into emergency mode), whereof no burner ignition could be effected. The manufacturer cannot be held liable for improper mounting and installation!

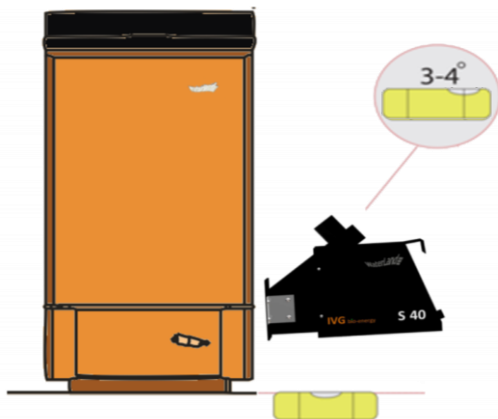

3. The temperature sensor (See Fig. 1. - 12) shall be mounted in a specially designed socket, at the side of the boiler.

The temperature sensor shall be installed so that good contact and heat exchange with the metal surface is assured, as well as to avoid accidental dismounting or displacement.

CAUTION! Failure to comply with the requirements of the previous item 3 would result in risk of boiler overheating and undesirable consequences, since protective devices depend on actual temperature readings of this particular sensor. The manufacturer cannot be held liable for improper mounting and installation! A mechanical emergency thermostat shall be

installed to the boiler /included in the set/, so that controller electrical power supply be cut off (AC 220-230 V).

4. Boiler hopper shall be mounted in compliance with the drawing provided:

5. The auger (See Fig. 1. - 5) shall be mounted to the pellet fuel hopper under an angle of 45° to the horizontal plain. Connect it to the burner as shown in the drawing.

6. The flexible pellet duct, connecting the auger to the burner, shall be almost vertical, so that no pellets stuck to it during operation (minimum 60 ° inclination). It can be shortened, if deemed necessary, but not under 250 mm (standard requirement).

7. The controller connector (See Fig. 1. - 9) shall be connected to the burner. Its disconnection or removal during operation would automatically stop the burner (switches to emergency mode).

8. The water pump (electrical drive) shall be connected to the EMC 1 controller, prior to its connection to the electrical power supply network (AC 220 - 230 V).

9. The auger connector (See Fig. 1. - 6) shall be connected prior to connecting the controller to the electricity network.

10. Plug in the power cable (See Fig. 1. - 2) to the electricity network AC 220-230 V.

11. Wait until completion of initial blowing (8-10 min.)

12. Fill the hopper and auger as shown below.

13. Hold the UP button for 3 seconds to start the burner.

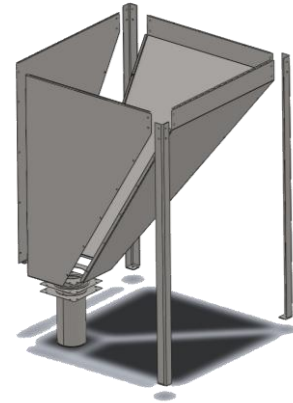

Requirements to the fuel

- ✓ Pellets shall be Class "A" (real).
- ✓ Recommended calorific value of fuel >4,7 kW/kg (under European standard);
- ✓ Pellet diameter - 6-8 mm;
- ✓ Humidity - below 10%;
- ✓ Ash content - below 1%;
- ✓ Pellets from conifer trees, without bark or other admixtures are recommended.

CAUTION!

Only good quality dry pellet fuel shall be used. It is recommended that the pellet fuel be stored in dry aired location!

Storage of pellet fuel in close proximity to the equipment is strictly forbidden!

It is recommended that the pellet fuel be stored in adjacent premises!

Upon installation of burner on site, all fire-safety regulations and requirements shall be complied with!

CAUTION!

The burner shall be installed in such a way as to allow easy servicing and maintenance. Burner installation in close proximity to flammable materials is not allowed, due to risk of fire!

The burner should be securely installed to the respective piece of equipment (boiler or another heat consumer), so that it can be removed without using tools, as well as being easy to service and clean from ash.

Installation and maintenance of the burner shall be performed by a qualified technician, certified by the manufacturer. Prior to commissioning the burner, proper operation of the heating system shall be assured.

Burner shall be serviced only by persons familiar with the installation and operation manual of the equipment.

6. Burner Description and Operation Manual

Auger Feeding and Adjustment

- ✓ Following the installation of the pellet burner, the auger capacity shall be tested as shown (Fig. 3.) The adjustment procedure shall be performed with each replacement of the type of pellets used.
- ✓ The auger shall be fed with pellets through commands from the controller in the following sequence:
- ✓ Enter the **"USER MENU"** by pressing the **"OK"** button.
- ✓ Select **"Automatic Adjustment"** sub-menu by pressing **"DOWN"**.
- ✓ Enter the **"Automatic Adjustment"** sub-menu by pressing **"OK"**.
- ✓ Select **"Auger Feeding"** by pressing the **"DOWN"** button.
- ✓ Enter the **"Auger Feeding"** by pressing the **"OK"** button.
- ✓ Start the auger by pressing the **"UP"** button.
- ✓ Wait until pellets start to emerge from the auger, i.e. the auger is full with pellets.
- ✓ Then read the time using a timer (clock) and stop the motor after 360 seconds by pressing the **"DOWN"** button.
- ✓ Measure the quantity of pellets in [g/6 min].
- ✓ Return to the **"Automatic Adjustment"** sub-menu by pressing **"C"** button.
- ✓ Using the **"UP"** button, select the **"AUGER [g/6min]"** menu.
- ✓ Enter the **"Auger Capacity"** by pressing the **"OK"** button.
- ✓ By using either the **"UP"** or **"DOWN"** buttons, select the nearest higher value to the measurements taken by you.
- ✓ Save changes made by pressing the **"OK"** button!!!
- ✓ Connect the flexible pellet duct to the burner auger.



Fig. 3

Cleaning

Switch off the burner manually, by pressing and holding the **"UP"** button for 3 seconds. Wait as long as the preset gas-dynamic cleaning time (8-10 min.)

During mechanical cleaning, the controller should be disconnected from the electricity supply network.

In view of your safety, the burner shall be allowed to cool down to a lower temperature. After disconnecting and cooling down, the burner is ready to be cleaned.

Remove the grate from the combustion chamber and clean it (Fig. 4.)!

Clean the combustion head as well as the area underneath the grate.

Reinstall the grate in its proper position, so that it interlocks with the drop (Fig. 4)!

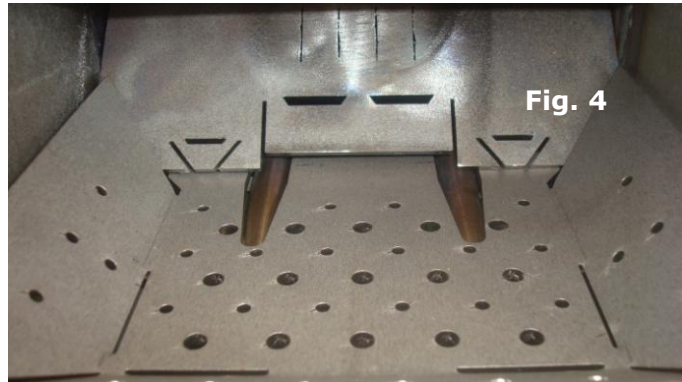

Clean the burner on a regular basis! Burner cleaning time interval shall be established based on your personal experience. It is recommended to clean the burner at least once weekly (from once daily to once weekly). The more often the burner is cleaned a greater economy is achieved and the less the risk from getting congested.

The use of a higher quality pellet fuel would result in cleaning the burner at longer time intervals.

CAUTION!

If using lower quality pellet fuel the burner should be cleaned more often due to risk from congestion and improper operation. Correct operation also depends on the cleaning of the boiler and the chimney as well. Clean them periodically!

Safety measures during burner operation

The operation of equipment is monitored by the controller. It manages the ignition and burning processes, reading data from the photo-sensor and the thermo sensor. In case of two consecutive failure attempts to ignite the burner, it switches to **"STOP"** mode, displaying the following warning on the screen **"Bad Ignition/Fuel"**.

During operation the burner can run out of pellets or get congested, whereof the controller will display an indication on the screen: **"Congest./No fuel"**.

A thermostat has been installed in the burner, preventing pellet inflammation and the so called reverse combustion. In case reverse combustion occurs, the controller will switch off the burner, moving into a **"STOP"** mode, whereas **"Emergency Stop"** shall be displayed on the screen.

Should such situation occur, disconnect the controller from the electrical network, take all necessary safety measures, such as protection against ignition or heat stroke and then carefully clean the burner. It is recommended to call an authorized service technician to establish whether the equipment is safe. Failure of the thermostat or melting of the flexible pellet duct is possible. To prevent reverse combustion check if the burner is clean, properly adjusted as well as the proper inclination of the burner, as set out in the installation instructions and requirements.

In case of disconnection or improperly connected plug, the burner automatically switches to a **"STOP"** mode, displaying an on-screen alarm **"Emergency Stop"**.

Unforeseen Risks During Cleaning and Servicing

Risk from Hand Burns (damage)

Possible cause - high temperature of the combustion chamber

This risk is related to unburned pellet fuel as well as cleaning the burner before it has cooled down sufficiently!

The risk might arise during cleaning or servicing the burner. It is recommended using special personal protection equipment (gloves)!

Electrical Shock Risk

Servicing the burner during operation or while connected to the electricity network is strictly prohibited! In case of short-circuit or failure, an authorized technical shall be called. Touching current conducting parts is prohibited!

Risk from Dust in the Eyes

The risk is related to cleaning, servicing or operating the burner. It is recommended using special personal protection equipment (protective tight-fitting goggles)!

CAUTION!

Periodical burner cleaning and monitoring would prevent failures cause by use of low quality pellet fuel, improper inclination of the burner and the auger as well as incorrect burning adjustments. Read the instructions manual prior to commencing installation and operation of the burner. The manufacturer cannot be held liable!

Language Selection

Connect the controller to the electrical network. The screen will display a language selection menu, Fig. 5. The user is prompted to select either Bulgarian or English (the option is supported by v. 11 or later software versions). The controller will keep the current state of the previous language selection. Using the **UP** and **DOWN** buttons, select the language of your choice and confirm by pressing the **OK** button. Upon power supply failure the controller would start, selecting automatically the last language choice made by the user.

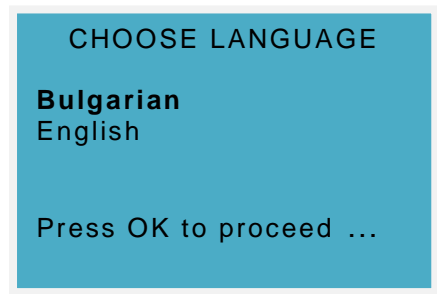

Display

The EMC 1 controller has been provided with a display visualizing the current burner state, as well as navigation buttons: **"UP"** and **"DOWN"** allowing navigation between the menu lines.

The graphic display visualizes the system state as follows:

Peripherals field: provides the following information (downwards):

- If the burner has been started or not;
- Current boiler temperature;
- If the water pump is switched on or off;
- Current burner capacity;
- Flame intensity;
- Current time - provided a weekly scheduler has been activated, the current time information field will consecutively change data by displaying the following warning: **"! TIMER!"**.

Messages field: Indicates the execution of burner algorithm set, visualized by displaying the following messages:

- Cleaning at START;
- ✓ Cleaning at STOP;
- ✓ Burner cleaning;
- ✓ GSM Start;
- ✓ GSM Stop;

As well as the following emergency modes:

- ✓ Defective thermo-sensor;
- ✓ Emergency stop;
- ✓ Congested/No fuel;
- ✓ Boiler overheating;
- ✓ Battery failure/Clock;
- ✓ Bad ignition/fuel;

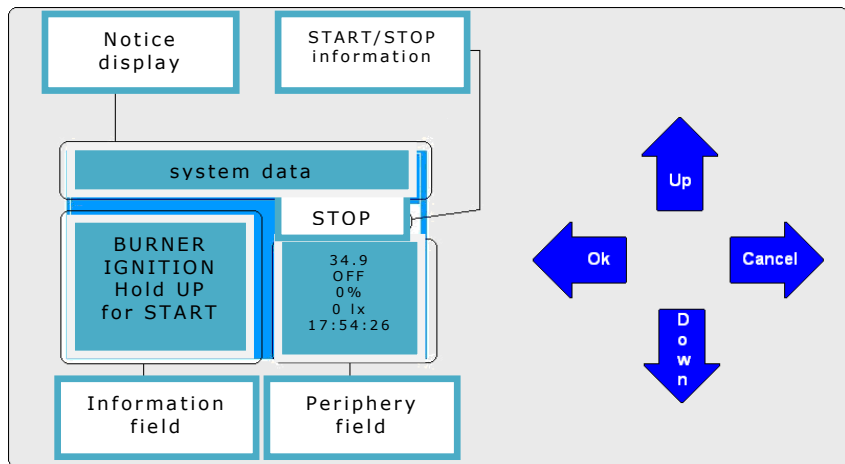

Information field: displays data from the selected peripheral field position and the burner status:

- ✓ Ignition mode;
- ✓ Operation mode;
- ✓ Pause;

Burner Ignition and Switch-Off

Caution!

Every time the controller is connected to the electricity network, the burner switches to "Cleaning at START" mode (8-10 min). Please wait. During this time the burner blocks some commands.

The "UP" button is used to START and STOP the burner (keep pressed for 3 seconds to Start or Stop it!).

Following pressing down the button for 3 seconds to START the burner, it switches into an "IGNITION MODE", following a particular preset program, after which the burner automatically switches into operation mode.

Following pressing down the button for 3 seconds to STOP the burner, it switches into a gas-dynamic cleaning at STOP (8-10 min), then it stops and is ready for another start.

User Menu

To enter the "USER MENU", press the "OK" button (Fig. 7). Using the UP and DOWN buttons the respective adjustments sub-menu is selected, then using the OK button to confirm selection and memorize the adjustment made. To exit the User Menu, press the "C" button (CANCEL).

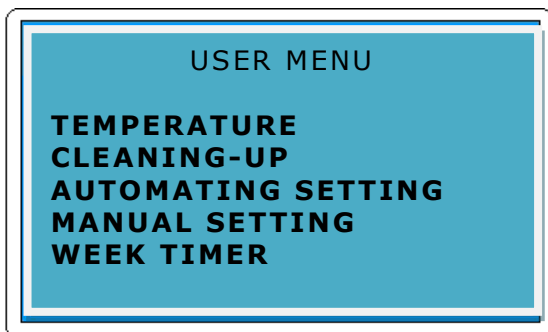

"TEMPERATURE"

Carries out adjustment to the desired boiler temperature and hysteresis (factory setting is 50° C and a hysteresis of 10° C). The same sub-menu is used to adjust the water (circulation) pump switch-on temperature (factory setting is 43°C).

"CLEANING"

A cleaning time interval is set in minutes and

duration of cleaning in seconds.

"AUTOMATIC ADJUSTMENT"

The factory system settings are preset to automatic adjustment. This sub-menu allows changing that to manual or automatic adjustment. The **"Automatic Adjustment"** menu allows selecting the required maximum capacity of the burner, among the following values: **16kW, 24kW** and **32kW** (select the value nearest to the capacity of the selected boiler type). Use the same sub-menu to set the auger capacity, depending on the quantity of pellets measured per 360 seconds, as described above (Fig. 3.) Upon completion of this operation, the controller automatically readjust the pellet dispensing software settings.

CAUTION!

If, following adjustments made to the weight, as shown in Fig. 3, aiming at determining the capacity, you notice pellet piling up (danger of congestion), increase the auger capacity by 2 or 3 steps.

This readjustment is required owing to the fact that different pellet manufacturers provide pellets of different density and bit length, which affects the actual auger capacity.

"MANUAL ADJUSTMENT"

This is a specific adjustment which requires having the necessary qualification!

It allows individual adjustment of burning, by setting individual parameters and time intervals!

- **"MINIMUM PELLETS"** is the minimum quantity of pellets at which the burner will not switch off at a 10% capacity mode.

- **"MAXIMUM PELLETS"** is the quantity of pellets defining the desired burner capacity at a 100% mode, monitoring the good burning of pellets in both modes.

The air adjustment is achieved through setting a maximum blower value at 100% capacity (in operating mode). To set that, enter the servicing menu, blower/fan menu and from the **"BURNING AIR"** sub-menu select, normally, 80%, 90% or 100%. Intermediate blower speeds during modulation are automatically calculated by the controller!

The speed shall be selected on a trial-basis, using a gas-analyzer, or by experience of the technician. It would also depend on the flue outlet exhausting power! The factory setting is 90%! (The same air adjustment of settings are carried out in **"AUTOMATIC ADJUSTMENT"**).

-**"PAUSE-PELLETS"** is set in accordance with the type of pellets used!

Pellet burning time for the same quantity of different type of pellets is different. The burning time can be between 15 and 45 seconds.

It is recommended that an authorized technical carry out this adjustment setting! Good pellet burning and economy on fuel depend on this adjustment!

CAUTION!

Provided incorrect values have been set the burner might switch off or congest (the burner switches into emergency mode).

"DATE AND TIME"

Input the current time and date.

CAUTION! When using a weekly scheduler correct adjustment shall obligatorily made. If no data, hour and minutes are set, the burner shall not be able to start properly using the weekly scheduler.

"WEEKLY SCHEDULER"

Allows the user to start or stop the burner on different week days and at different times of the day.

CAUTION!

Starting the burner using the "Weekly Scheduler" without setting the actual current date, hour and minutes from the "Day and Time" menu is not possible. In case a warning "Batt. Problem/Clock" has been displayed, activating the "TIMER" option is not possible! The burner cannot be switched manually by the user if the "Weekly Scheduler" has been activated, but it can be switched off manually which causes the "Weekly Scheduler" to deactivate.

*Monday	*Monday
Tuesday	YES / NO
Wednesday	M /Sat: 2
Thursday	M1 - 08:00
Friday	Sat1 - 10:00
Saturday	M2 - 14:00
Sunday	Sat2 - 20:00

"Weekly Scheduler"

Using this menu the "Weekly Scheduler" can be activated or deactivated.

Program the "Weekly Scheduler"

Select the week days on which you would like to start the burner.

Select the week day desired by using the **"UP"** and **"DOWN"** buttons and use the **"OK"** button to enter the respective sub-menu (Fig. 8.)

Mark the day using **"YES"** or deactivate it by selecting **"NO"**.

Set the desired number of start-ups and stops (1 or 2) - **"Start/Stop"** for the respective day, as well as the hour and minutes on which the respective **START and STOP** shall occur.

Using the **OK** button confirm the changes made, whereof an asterisk (*) shall appear before the respective day.

"Save Changes"

Upon making changes to the **"Program Weekly Scheduler"**, save any changes made by pressing the **"OK"** button.

Servicing Menu

CAUTION!

It is highly recommended that only authorized technicians and company distributors enter this menu!

This menu allows adjustment of the ignition system and burning air!

Keep the **DOWN** button pressed and also press **"C"** (CANCEL) button to enter the servicing menu. To exit the menu press the **"C"** (CANCEL) button.

"IGNITION"

It is recommended to use the factory settings in this menu!

It is used to adjust all settings and parameters relating to ignition of the burner:

- **"Initial Dose [s]"** - used to set the pellet quantity for initial ignition. As a criterion for setting this time interval is used the time for full coverage of spark plugs with pellet fuel.
- **"Dose Burning [min]"** - sets a time interval sufficient for full burning of the first dose of pellets.
- **"Photo sensor Limit [Ix]"** - minimum photo sensor threshold to switch off the **"ignition"** program/mode.

"IGNITION TIME"

The ignition time defines the period between two ignition attempts of the burner in case of failure.

In case of second ignition failure, the burner switches into an emergency mode, whereof a message "**Bad ignition/fuel**" is displayed on the screen.

"BLOWER"

This menu is used to set the gas-dynamic time periods of burner cleaning at START and STOP, as well as regulating the maximum air during ignition and in operating mode.

CAUTION!

The time intervals of burner cleaning at START and STOP shall obligatorily be between 8 and 10 minutes. Setting lower values for those time intervals would lead to improper equipment operation.

It is possible to decrease the gas-dynamic burner cleaning time at START to 1 minute upon initial installation, without saving that value, to achieve installation time-saving to the installation team. It is then obligatory to restore the original factory setting (10 minutes) and save it by pressing the "OK" button.

7. Basic Technical Specifications and Parameters of EMC 1

Dimensions	175x130x60
Display	LCD graphic display 128 x 64
Memory	Independent by power supply
Clock / Weekly Scheduler	Independent by electricity network
Battery (clock)	Enables the current EMC time for a period of 10 years. CAUTION! Battery replacement shall obligatorily performed by authorized technicians or repair services!
Sensors	Temperature sensor, Light sensor and Thermostat
Operation at Ambient Temperature	5°C - 45°C
Humidity of Ambient Environment at 30°C	95%
Power Supply	220 – 240V 50-60Hz
Electric Power of EMC 1	- "standby" mode: 0, 0014 kW - "start" mode: 0, 396 kW - "operating mode": average below 0,08 kW

CAUTION!

The burner controller shall be plugged into an earthed socket. In the absence of earthed socket there is current rush hazard! The manufacturer cannot be held liable!

Emergency Protection of EMC 1

1. **"BOILER OVERHEATING"** - Protection from boiler overheating at and over 95°C (read by the thermo sensor). This protection triggers emergency burner stop. No starting by user is possible until temperature drops under 95°C.
2. **"FAULTY THERMO SENSOR"** - Protection at faulty, not installed or cut off thermo sensor-to-boiler cable. The communication cable between the device and the sensor might be cut. The sensor casing might be damaged. The burner performs an emergency stop and cannot be started by user.
3. **"Congest. \NO FUEL"** – Burner protection resulting from incorrect user adjustment settings, bad pellet quality or on running out of pellets. Possible Photo sensor contamination.
The controller establishes lack of light to the photo sensor and stops burner. Clean the burner from ash and slag and fill the pellet hopper with pellets.
4. **"EMERGENCY STOP!!!!"** - Protection from disconnected EMC1 connector to the burner or upon boiler achieving the critical temperature of 95°C and/or protection from reverse combustion of pellets into the metal pellet duct. The device stops automatically and cannot be started until plugging in the connector, temperature drops below critical or cause of reverse combustion have been eliminated (a reverse combustion thermostat might have got faulty).
5. **"Battery/Clock Problem"** – Protection from failure to set current date and time or clock battery discharge. This alarm prevents weekly scheduler control of burner in such cases. Set he current time into the controller. In case of discharged battery, it should be replaced by an authorized service.
6. **"Bad Ignition/Fuel"** – Burner protection from incorrect adjustment settings to the controller, improperly leveled burner, bad quality or damp pellet fuel as well as blown heaters. This alarm prevents the burner from a second ignition attempt.

8. Electrical Drawing

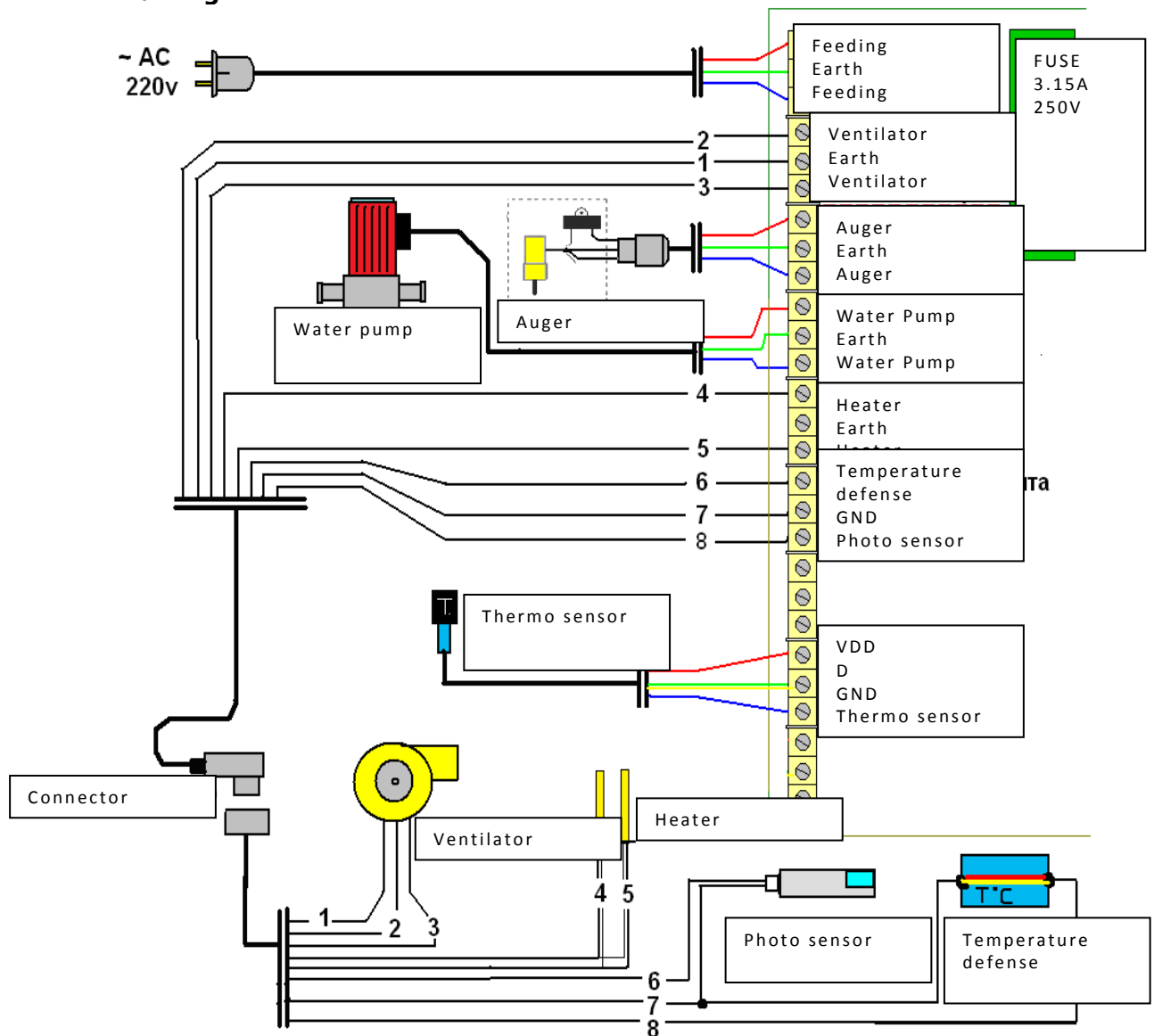

1. The fuse shall be 3.15A!!! Please, do not replace with fuse of different specifications.
2. Upon connecting the water pump to the controller, make sure that the power does not exceed 200W. If pumps of larger capacity shall be controlled, use circuit switch.

CAUTION!

Upon failure, the equipment shall be repaired by authorized service technicians. With view to your safety, dismantling covers and repairs carried out by unauthorized persons is strictly prohibited. Non compliance with the above conditions would render the warranty void, and the manufacturer shall not be held liable.

9. Troubleshooting

Some of the most probable faults and troubleshooting methods have been described herein, which, in the majority of cases, are the result from improper operation or adjustment setting of the equipment.

FAULT	CAUSE	TROUBLESHOOTING
<p>Dark display screen. The controller is out of order.</p>	<ol style="list-style-type: none"> 1. The power supply cable of the controller is not connected to the electricity network. 2. No voltage: AC 220-230V 50Hz; 3. Controller input fuse blown; 4. Defective fuse due to short circuit to the water pump; 	<ol style="list-style-type: none"> 1. Connect the power supply cable to the electrical network. AC 220-230V 50Hz; 2. Check voltage of socket: AC 220-230V 50Hz; 3. Replace the defective fuse with 3.15A new one; 4. Check if water pump corresponds to the capacity declared by the manufacturer; In case of failure to eliminate the above faults, call an authorized repair service!
<p>The burner does not start</p>	<ol style="list-style-type: none"> 1. Protection activated due to critical temperature of the boiler 2. Activated reverse combustion protection (thermostat) - "Emergency Stop", the burner is congested with ash/slag, reduced exhausting power due to congested flue duct and/or unclean boiler (flue ducts or jackets). 3. Unplugged controller-to-burner connector - "Emergency stop"; 4. Weekly Scheduler activated, the burner cannot be started by the "UP" button; 5. The burner is in "Cleaning at START" or "Cleaning at STOP" mode (blower working at full capacity). 	<ol style="list-style-type: none"> 1. Start the burner when the boiler temperature drops below the one set by the user, checking all system components beforehand. 2. Clean the chimney, the boiler and the burner! 3. Connect securely the connector to the burner; 4. Deactivate the Weekly Scheduler if not intending to use it; 5. Wait for the required cleaning time to elapse and activate the START command.

<p>If the following are displayed on the screen: "Bad ignition/fuel"</p>	<ol style="list-style-type: none"> 1. Improperly placed grate in the combustion chamber; 2. Unclean, contaminated or congested burner; 3. Bad quality of pellet fuel; 4. Faulty photo sensor, possible sensor contamination; 5. Blown spark plugs; 6. Incorrect "IGNITION TIME" set 7. Improperly leveled burner (greater incidence than shown in Fig. 2) 8. Incorrect "First Dose [s]" set 	<ol style="list-style-type: none"> 1. Place the grate in position; 2. Remove grate and clean the burner from ash, slag and pellets; 3. Increase ignition time at the controller or change fuel; 4. Check the photo sensor. It shall not be contaminated. Clean or replace the photo sensor. 5. Check for faulty spark plugs. In case of faulty heater, replace with new; 6. Increase the "IGNITION TIME" value, it should be at least 6 min.! 7. Perform proper leveling in compliance with the installation instructions, Fig. 2. 8. Check if pellets cover the heaters, increase "First Dose [s]";
<p>If the following are displayed on the screen: "Congested/No fuel"</p>	<ol style="list-style-type: none"> 1. Too high or low value set for "Ignition Dose [min]" 2. Incorrect burner adjustment settings; 3. No pellet fuel in hopper, causing the burner to switch off. 4. Congested burner due to low quality pellet fuel, improperly placed grate or improperly installed burner. 	<ol style="list-style-type: none"> 1. Set such a value for "Ignition Dose [min]", so that the first dose has caught fire to the middle of the grate at least (4-6 min.). 2.1 Change cleaning times. Increase the cleaning time value. Decrease time intervals between cleanings. 2.2 Insufficient pellet dose burning time at 100% capacity: <ul style="list-style-type: none"> - Increase the capacity of the auger set (in "User Menu", sub-menu "Automatic Adjustments", sub-sub-menu "Auger Capacity"), thus automatically decreasing the auger pellet-feeding time. - If the burner is set to manual mode of operation, increase the time value for "PELLETS PAUSE" (only by an authorized technician!!!) 3. Check the quantity of pellets in the hopper. If run out of pellets - feed pellets to the hopper! Charge auger with pellets using the controller! 4. Change the pellets used with better quality pellets! (Low quality pellets are on offer at the market. Don't be misled into thinking that using low quality pellets would

		result in achieving the required effect.) Check if the grate is properly installed (See Fig. 4). Check if the burner is properly leveled (See Fig. 2).
If the following are displayed on the screen: "Boiler overheating"	1. High value set of the boiler working temperature, with a high hysteresis;	1. Decrease the boiler working temperature value from the "Temperature" menu;
If the following are displayed on the screen: "Emergency stop"	1. Unplugged controller-to-burner connector - 2. Activated reverse combustion protection of the burner;	1. Connect securely the controller connector to the burner; 2. This can occur only in case of congested chimney, boiler or burner covered by soot or slags - CLEAN THEM!!!
If the following are displayed on the screen: "Batt. failure/Clock"	1. The user has not set date and time in the controller; 2. Discharged battery;	1. Set current date and time in the controller; 2. Check if battery is faulty with an authorized repair service;
If the following are displayed on the screen: "Defective thermo-sensor"	1. Controller-Thermo sensor communication problem; 2. Faulty thermo sensor;	1. Check for faulty thermo sensor-to-controller communication cable; 2. Call an authorized repair service;
Burner switches off at low capacity manual mode	1. Incorrect burning adjustment settings; 2. Burning time value set is too high;	1. Set correct burning values from the "Manual mode/Min. Pellets" menu; 2. Burner switches off if too high a value has been set to "Pellets Pause". Decrease the burning time value from the respective menu.
The burner switches into cleaning mode without of its own accord.	1. Power supply faults. 2. Photo sensor fault	1. Check socket or connection block. Replace with new. Probably faulty power supply, intermittent power supply. 2. Check the photo sensor for contamination or reposition correctly.

<p>Significant difference in data readings of boiler and controller temperature gages. Boiler overheats.</p>	<ol style="list-style-type: none"> 1. Poor thermo contact of heater with boiler and controller thermo-sensor. 2. The controller thermo sensor installed in improper location in the boiler . 3. No physical contact of controller thermo-sensor with the water jacket of the boiler . 	<ol style="list-style-type: none"> 1. Attach tightly the thermo-sensor to the water jacket of the boiler or to the factory thermo-coil (if provided). Provide thermo-insulation from ambient air (it is possible that cold air cools it down). 2. Attach tightly the thermo-sensor to the water jacket of the boiler above the temperature gage or in its thermo-coil (if provided). 3. Make sure the thermo-sensor has been installed extremely tightly and reliably in its proper place in the boiler ! Secure it so that the cable cannot be unplugged or separated from the boiler , but get cut! (In case of cable cut the controller switches to emergency mode indicating "FAULTY THERMO-SENSOR". This is of crucial importance for the heating system safety.
--	--	--

10. Cleaning Instructions

During cleaning the burner shall be disconnected from the mains.

The burner shall be left cooling down. After disconnecting and cooling down, the burner is ready to be cleaned.

The burner shall be free of the coupler with the cover removed. Release the burner from the screws holding it down to the boiler .



The burner shall be cleaned on a regular basis and whenever required. This will insure that the burner works as economically as possible. The more suitable the boiler and higher the pellet quality, the longer the cleaning intervals can be.

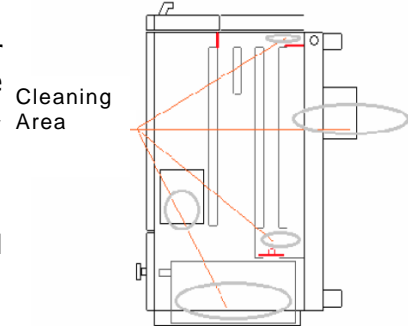

Boiler ...

The ash should be removed from the boiler , whereas all surfaces should be brushed to remove deposits.

Burner Heads ...

Ash and embers shall be removed from the grate. Ash and ember leftovers shall be removed from beneath the grate. The burning sensor /photo sensor/ shall be cleaned. Check the blower for foreign particles.

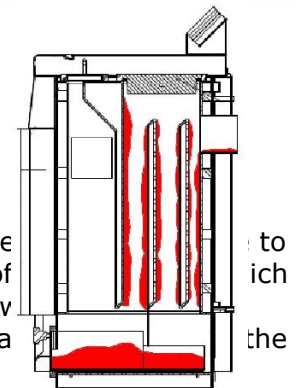

Pellet Hopper ...

Since pellets stored in the hopper contain sand, the hopper shall be cleaned regularly. The more the sand quantity in the hopper the less quantity of pellets might influence the adjustment settings or cause the burner to stop working. The frequency of hopper cleaning depends entirely on the hopper weight and the quality of pellets used.

Commissioning After Cleaning ...

The burner shall be reinstalled in reverse sequence to that of dismantling and then ignited (the button shall be kept pressed for about three seconds, whereof the burner shall automatically start).

Maintenance Instructions

Proper pellet burner maintenance assures trouble-free operation.

If required	Weekly	Every two weeks	Monthly	Every six months	Annually	
X	X	X				Cleaning the burner head in the presence of hardened ash deposits.
		X	X			Cleaning dust and ash underneath the grate of the combustion chamber.
X			X	X		Cleaning the photo sensor from dust and soot
				X	X	Cleaning the blower from dust; It is important to replace faulty parts immediately.
X		X	X			Cleaning the burner and the boiler
X			X	X		Cleaning the flue duct to the chimney and the rear side of the boiler
					X	Checking the sealing and replacement if warned-out.
X						Adjustment of Burner ...
				X	X	Cleaning of the hopper
					X	Chimney cleaning

The maintenance schedule is advisable, whereas cleaning shall be performed whenever necessary.

Cleaning time interval requirement is individual, depending on the choice of pellet, the system and the burner adjustment settings.

IT is important that faulty parts be replaced immediately.

A spare photo sensor and spark plug /heater/ shall be made available at all times.

A burner with correct adjustment settings will work well and efficiently. In case of problems, contact your supplier for troubleshooting or burner adjustment.

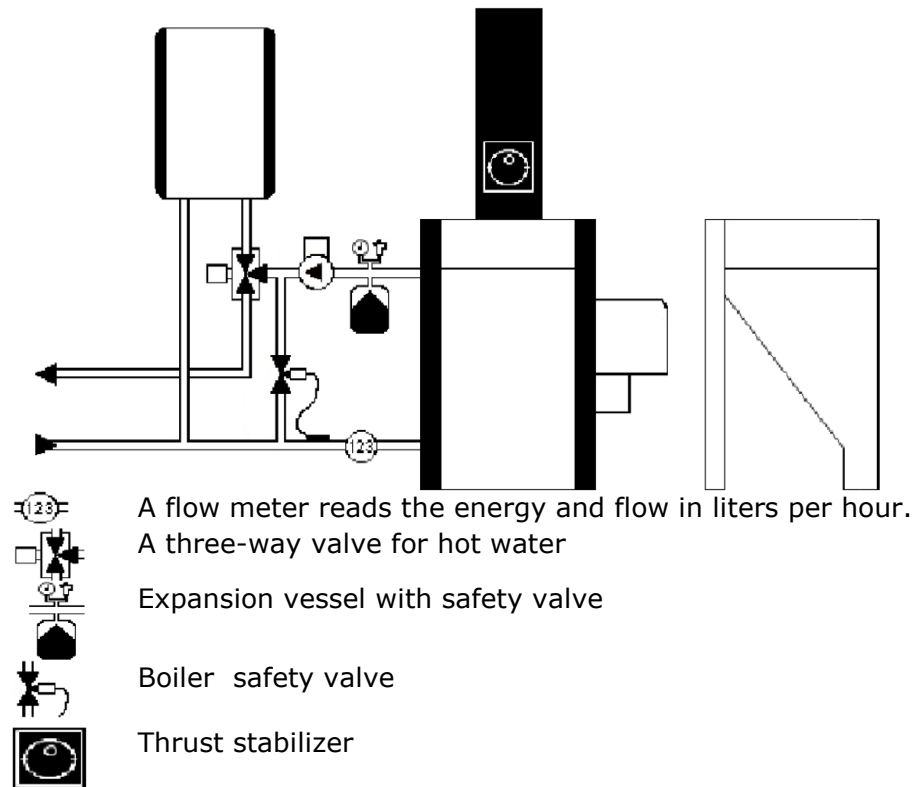

11. Pellet Hopper Installation

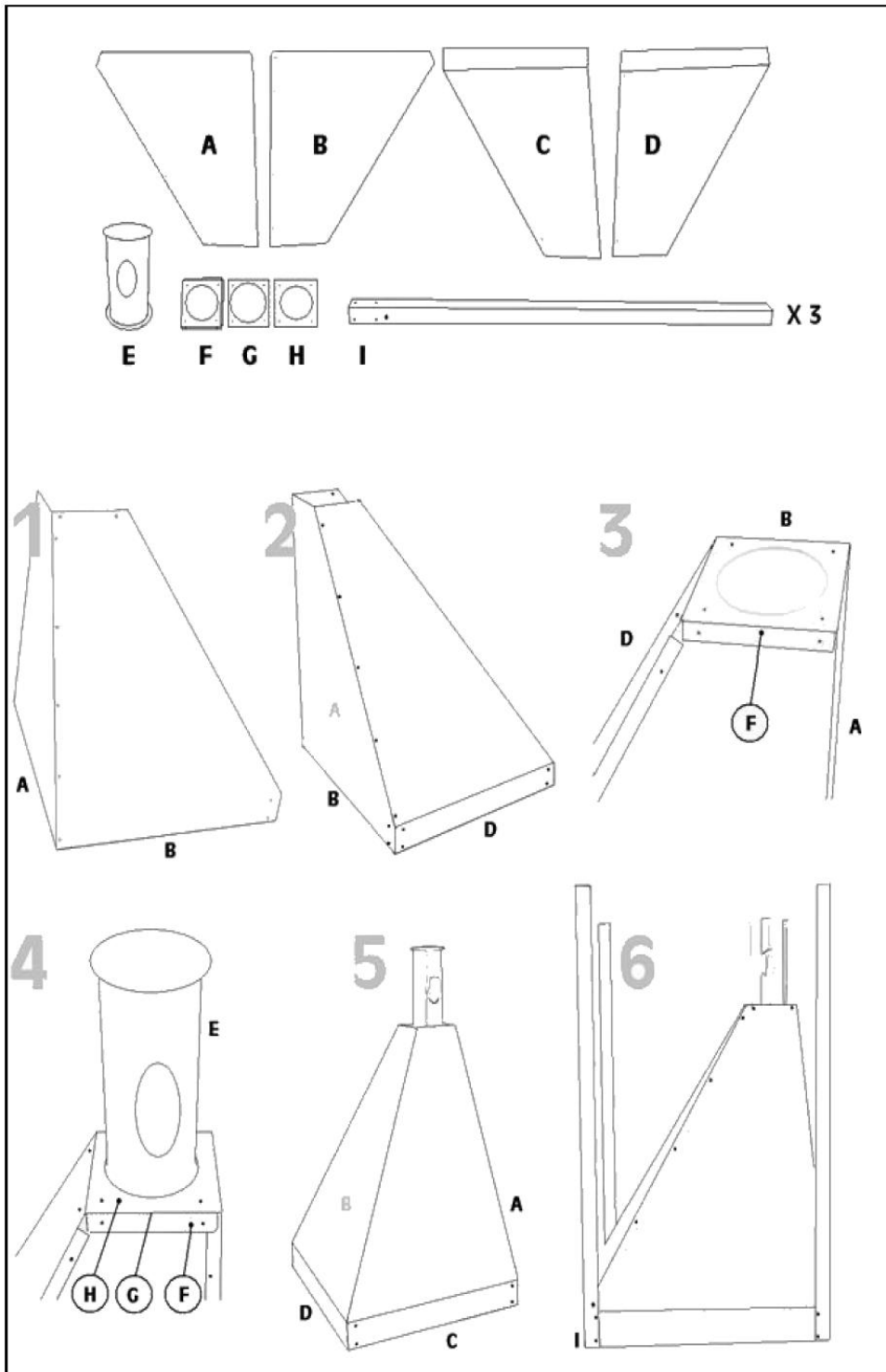

Warranty Card

Buyer:	Installation carried out by:
Name:	Company name:
Surname:	Technician:
Surname:	Installation date:
Address:	Address:
Town/village Postal Code:	Town/village: Postal Code:
Street/Bl.:	Street/Bl.:
Entr.: Apt. Contact telephone:	Entr.: Apt. Contact telephone:

Warranty Conditions:

The warranty period of the equipment is 5 years for the water chamber and 24 months for all other parts starting from the date of sale, subject to compliance with all requirements for proper transportation, storage and installation.

The warranty shall be considered void in case of installation performed by unauthorized specialists, using low quality or components different from the original ones.

Important! The warranty shall be considered valid upon presenting an invoice and a warranty card legibly filled out.

List of warranty period repairs made

Date of submission to repair service	Description of defect	Date of return to customer	Signature of the repair technician

BG Term OOD

City of Sofia 17 "Acad. Stefan Mladenov" Blvd.

Tel.: 02 /969 71 00, Fax: 02 /862 54 11, Fax:

www.bgtherm.com