

INSTALLATION AND SERVICE INSTRUCTIONS FOR HOT AIR FIREPLACE INSERTS

from **BeF Home**



Important:



- Inform your local chimneys sweep!
- Read the complete installation and service instructions!
- Keep to the regulations and orders of these instructions during installation and service of this fireplace insert!
- Keep to the appropriate standards during fireplace insert installation and service!
- Keep these instructions in a safe place!
- These instructions contain the Equipment Certificate!
- We recommend ordering a professional firm to install the insert.

Hot air fireplace inserts in accordance with EN 13 229 – W

Congratulations!

You have chosen a product of high quality, the hot air fireplace insert. Read carefully these service instructions. You will get the information about function and operation of your fireplace insert; you will increase its value and its service life.

Also you can save fuel and protect the environment. An Equipment Certificate is included (you can download it also on www.befhome.com). We ask you please to read this manual as well as the instructions for your specific model before beginning the installation.



We can provide a guaranty for our products only when the installation and service instructions are kept.



Essential requirements

- It is necessary to ensure that the whole unit with connecting piece and chimney will be safe during operation. The whole unit must be safe and easy to clean.
- THE DATA OF SAFETY PRECAUTIONS FROM THE POINT OF VIEW OF FIRE PROTECTION IN ACCORDANCE WITH NATIONAL STANDARDS.
- Be especially careful to maintain a minimum distance from any combustible subjects during the fireplace installation in the standard, according to national norm.
- The minimum safe distance from combustible material with combustibility degree of B, C1 and C2 is min. 200 mm. For a combustibility degree of C3 and for unsubstantiated combustibility degree in accordance with national technical standards and regulations it is necessary to double the distance.
- The unit may be used in a normal environment in compliance with national technical standards and regulations. When this environment changes and there could be a temporary fire or explosion risk (e.g. at work with paint substances, at linoleum mounting, etc.) the unit must be removed immediately.

Note: The fireplace insert must be situated a safe distance from other room equipment



Information about the combustibility level of some construction materials



The combustibility level of the construction material

A incombustible – granite, sandstone, concrete, special pargeting, bricks, ceramics facing

B hardly combustible - gypsum plasterboard

C1 hard combustible – leafy wood, plywood, hardened paper

C2 medium combustible – cork sheets, indie-rubber, floor material

C3 light combustible – wood-fibre sheets, polystyrene, polyurethane, PVC

Position

Fireplace inserts can be positioned only in rooms and in places which are risk free. There must not be any electric wires in walls and in ceilings where a jacketed chimney insert is installed. In rooms where a fireplace insert is situated there must be sufficient fresh-air inlet for combustion. The base where the fireplace insert is situated must be made and must be large enough to allow the firebox work correctly.



Fireplace inserts must not be located



- on stairways (excerpt houses where a maximum of two flats are situated)
- on corridors open to the public

- in rooms, where easily combustible or explosive materials or mixtures are stored or manufactured
- in flats or areas which are aired only by means of ventilators or hot-air heaters when a safe function of an open fire is not ensured with the help of the recommended stand and tube

Heating output

Bear in mind the information written on the insert design description. The heating potential of the fire depends on the output stated. Output is applicable to rooms which correspond to the Heat Safety Protection. In rooms which are more than 200 cubic metres it is necessary to count the heat consumption.



Fireplace insert location and combustion air inflow



The area must be provided with at least one door which leads into an open space, or with a window which can be open, or it must be connected with other rooms. Only rooms of the same flat or dwelling are counted. If there is not enough the room where the fireplace insert is located, must be provided with a tube:

- which leads directly into the fireplace insert (see pict. 01) and supplies minimum volume of convectional air. When the fireplace insert is connected with outer air it must be installed on the original stand which is supplied by manufacturer.

- it is necessary to take deformation resistance into account during tubing batching, especially during curve, branch pipe or long pipe installation.

- for combustion air which leads into an open space and supplies at least 360 m³/hour of combustion air 1 m² of firebox hole (see pict. 02). This tube must be connected directly with the fireplace insert. If other fireboxes are located in a heating interconnection at least 540 m³ of combustion air 1 m² must be supplied into the firebox. To other fireboxes except this at least 1.6 m³ of combustion air / hour and on each kW of total nominal heat output when the initial pressure difference was at least 4 Pa as compared to an open space are needed (except fireboxes which are located in areas that do not depend on air in a room, do not need a smoke flue or are located in areas where the operating safety of inserts cannot be endangered).

- it is recommended that combusting air is supplied towards a fireplace in a convection area.
- it is necessary to arrange tubing for combusting air in buildings with more than two floors, as stipulated by local building regulations, and tubings for combusting air which connect antfire walls, so that fire and smoke cannot spread into other floors or fire compartments.



It is possible to use data from the Equipment Certificate when setting the dimension of combusting air flow piping (Inflow of air/hour)

Ask your chimney sweep or fireplace builder for assistance.

Adequate chimney

A fireplace insert must be connected into a chimney in accordance with national technical standards and regulations. Connection must be done only with with the approval of chimney sweep. The chimney must be directly connected, dry and lined with fire-bricks. If the fireplace insert should be connected to a chimney already built, it is necessary to clean the chimney and a chimney sweep must check its tightness and condition. A chimney sweep also checks if the chimney is suitable for fireplace insert connection. In case when the chimney does not exist or it is not suitable the new chimney dimensions must be according to the Equipment certificate. Low effective height limit of a stack flue is 5 m if counted from the discharge of combustion products slot. In single cases it is possible to connect even to a stack flue with less effective height than 5 m. It must be documented by a calculation of combustion products way that this height is enough for the connection. The fireplace insert must have its own chimney.

Chimney parameters

Chimney parameters in line with EN 13384-1 are found in the Equipment Certificate

Ceiling (floor) protection

pict.3

Ceilings without a sufficient lateral distribution (e.g. wooden ceilings) must be protected by a 6 cm thick concrete layer and 6 cm thick thermal insulation layer, where the fireplace insert is situated. Consulting a structural engineer is recommended. If the floor, where the fireplace insert will be situated, has an adequate lateral distribution a 6 cm thick thermal insulation layer is enough.

The floors in front of the fireplace insert

A floor made of combustible material in front of the fireplace insert must be protected by an adequate non-combustible material layer. Dimensions of this non-combustible area must be at least: 800mm in the sideways direction of the opening side (min.dimension H on pic.3) and 400mm to the front in the direction of the opening side (min.dimension S on pic.3)

- 1 – smoke flue
- 2 – fireplace insert
- 3 –bottom of the hearth
- 4 – surround
- 5 – floor

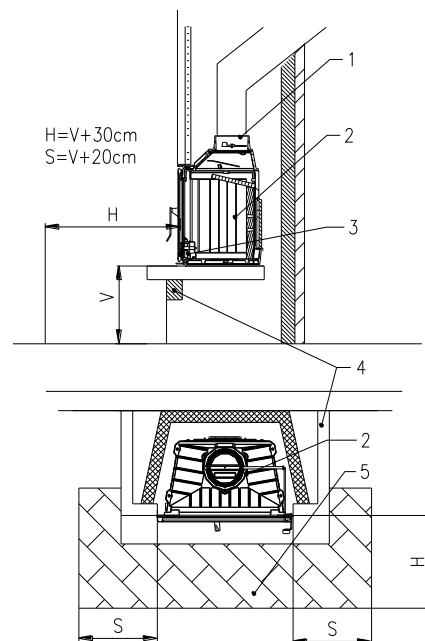

Schema of fireplace inserts installation

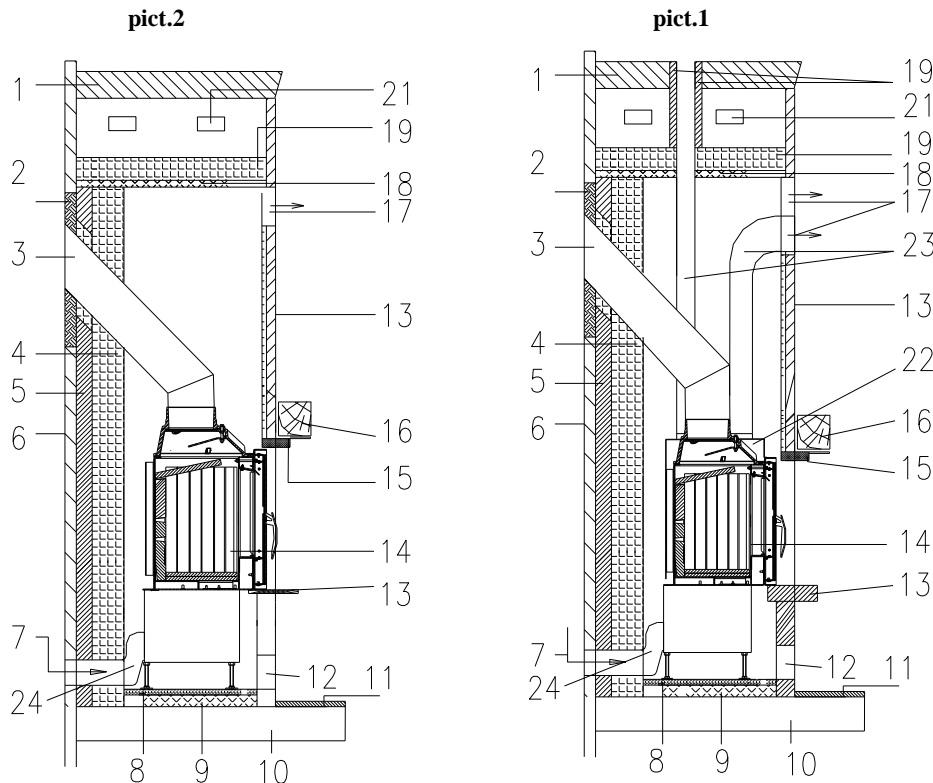

The fireplace insert is made in accordance with EN 13229 without the convectional air coating, made in the company (pic.2) and with the second rating (pic.1)

1. Protected ceiling made of combustibile construction material or as a carrying element
2. Substitutive building material: thermal prevention precautions performed
3. Connecting pieces made of steel sheet
4. Thermal insulation layer: back wall, side wall, ceiling, convectional air chamber (see page. 4)
5. Brick veneer
6. Protected wall made of combustibile construction material or a conductive element made of concrete or iron concrete
7. Protecting grille
8. Thermal insulation layer
9. Support plate
10. Protected base plate made of combustibile material or a support element
11. Anti-dazzle floor protection made of non-combustibile material
12. Convection air input
13. Coating
14. Fireplace insert
15. Support frame
16. Ornamental beam
17. Air outlet grille
18. Support element (fire resistant material)
19. Heat insulating layer (substitution of veneer), 6 cm thickness
20. Butterfly valve of external air
21. Interspace venting
22. Covering
23. Air distribution
24. Combustion air piping connection

The chimney connection

If the existing chimney is not provided with a suitable connecting fitting for the fireplace insert, it is necessary to make an additional connection. The chimney connection height is arrived at the properly situated fireplace insert and an attached smoke flue elbow and a connecting fitting – measured from the top edge of the support plate to the centre of the connecting fitting in the entrance of the connecting area. Gaps for the surround, insulation, expansion joint, etc. must be taken into account.

Brick veneer and thermal side and back wall insulation

The brick veneer and thermal insulation can be made after the suitable chimney connection.

Required brick veneer and thermal insulation

- Minimal thermal insulation of protected building panels was defined during the test of fireplace insert in accordance with EN 13229. During the test the thermal insulation made of cellular calcium-silicate slabs was used $\rho = 250\text{kg/m}^3$. It is necessary to use this kind of material in the prescribed minimal thickness. Other insulation materials must be of the same or lower thermal conductivity and a comparable thermal resistance!
- **Brick veneer:** a 10 cm thick mineral brick veneer must be made exactly on the protected building wall (back wall, where appropriate side wall). The brick veneer must abut onto the insulation layer and on the protected building side. It must over-lap the connecting piece (venting) upwards by at least 20 cm. The insulation brick veneer is not necessary when the building wall is 10 cm thick at least and is not made of combustible material and it is not a long bearing reinforced concrete wall.
- **Ceiling of the room above the insert (brick veneer replacement):** if the open space or the coating above the insert reach the room ceiling, it is necessary to protect the ceiling when it is made of combustible material or it serves as a carrying element. The protection consists of a 6 cm (better is 10 cm) thick thermal insulation layer (insulation material index: 12.07.21.75.11 according to AGI Q 132). It is recommended to take this preventive measure as a base intermediate floor (e.g. made of sheet-metal) with the insulation material situated above it. If there is a gap between the ceiling and the insulation, there must be diagonal venting for the gap (2x grilles min 50cm²)!

▪ **These preventive requirements have been set:**

Brick veneer	back wall	100 mm
	side wall	100 mm
Brick veneer replacement, insulation acc. to AGI Q 132	ceiling in the surround	60 mm
Thermal insulation layer	floor	30 /30 mm*
	side wall adjacent to the wall	100 mm
	back wall	100 mm
	side wall non contiguous to the wall	50 mm
	convection air ceiling	100 mm
Min. distances of the fireplace insert from the inner side of the insulation	back wall	70 mm
	side wall	70 mm
	distance of the bottom of the hearth from the floor	130 mm
	distance of the top part of the fireplace from the ceiling	500

*floor 30 mm, + 30 mm of insulation under the fireplace insert /mind the air inlet/

- **Thermal insulation:** convection coating and convection access plate (outer contour of the facility) need to be coated from all sides by the thermal insulation layer. The thermal insulation must be without joints and must overlap each other on the sides. If these insulating boards are not fixed on walls, on coating or on abutting boards, it is necessary to fix them about 30 cm apart. The coating inwards the room (aperture) does not need to be insulated when the insert is designed in such a way that the coating surface and the surface on the wood storing chamber could reach a maximum temperature of 85 °C. For surfaces made of mineral construction material, except for the areas where objects could be detached, the maximum temperature is 120 °C. Thermal insulation layers made of rock wool or comparable material must be thoroughly coated from the room side and convection air area as a protection against fibre fraying.

If the connecting piece is passing through building elements of combustible materials (for example protecting walls), it is necessary to take measurements in accordance with national technical standards and regulations.

Permitted thermal insulation material and material for brick veneers (minimal requirements)

- **Thermal insulation:** cellular calcium-silicate slabs $\rho = 250\text{kg/m}^3$, mineral wool boards, ceramics fibre boards.
- **Brick veneer and surround:** Liapor, bricks, concrete, no-fines concrete, stone.
- **Alternate brick veneers and thermal insulation material:** must be authorized. They must also fulfil every requirement for thermal insulation and surrounds. Further information about these construction materials can be obtained in specialized stores.

Fireplace insert connection

- After insulation the fireplace insert can be connected by the connecting piece to the chimney. The fireplace insert is connected with the help of the smoke flue made of sheet metal with the max. length of 1.5 m. the smoke flue must be provided with the safety pin to protect it against sliding. When the connecting piece goes through parts with combustion materials (e.g. protective walls), it is necessary to keep instructions in compliance with national technical standards and regulations.



It is not allowed to put any other attachment which is not approved by the manufacturer into the chimney connection. There must be a safety pin on the smoke flue bellmouth to prevent slippage or turning out!



Fireplace insert with pull-up system door must be veneered to allow service and repair works. Veneer in the top part above the door of fireplace must be built up from easy demountable material (Calsil etc.), or there must be service opening in the place of bearing (grilles, thinning of coating etc.). Frame in the front part of insert with pull-up system must be built-in in accordance with scheme. It allows later demounting in case of pull-up system service



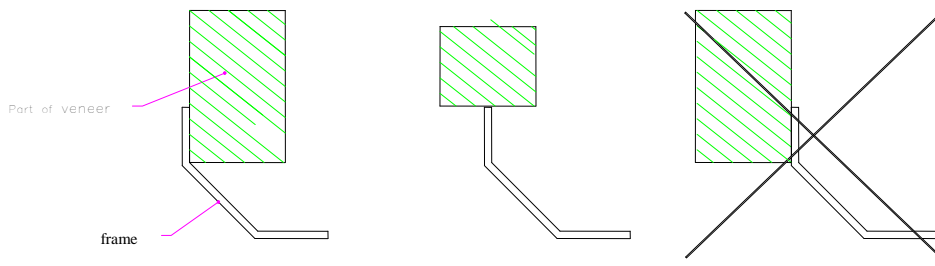

Convection air holes

In the top part of the surround, it is necessary to provide non closable convection air holes for a convection air output, in the bottom part, there is a need of convectional air input - minimal diameter depends on output of the fireplace insert, mentioned in the Equipment certificate. You need to consider non effective parts of the grilles (20-40% of the grille area, depending on design also) when choosing the convenient grilles for input/output of the convectional air and take into account also way of the using (in Equipment certificate, nominal output of the fireplace insert is mentioned and the real output depends on the amount of wood in use, the real output can be for short period higher of 50%). The minimal dimensions of the convectional air grilles for input and output are mentioned in the following chart:

Fireplace insert output (kW)	Convectional air input – grille dimension (cm ²)	Convectional air output – grille dimension (cm ²)
6-9	700	1000
10-15	850	1200
15-20	1100	1600



*After the fireplace installation neither the air input nor the air vents can be restricted by building panels.
We recommend ordering a professional firm.*



To prevent heat accumulation, the holes for convectional air must be open during heating. No lockable grates, ribs, blinds etc. can be installed into the holes. In the top part the convection coating must be finished by the partition wall above the hole so as not to make a thermal pocket (See surround diagram).

Convection cross-section between the insert and the coating as well as the insulation on the rear side – please check the chart with measures of protection (see p.6)



Note: These minimal distances in accordance with the Equipment Certificate must be kept to on all heights and widths of the fireplace insert so as to allow convection air to flow through.



- Convection air area: If a prefabricated area for convection air is not used (lining made of a galvanized sheet), it is necessary to maintain a distance according to data mentioned on the Equipment Certificate between the fireplace insert and rear thermal insulation layer.
- The fireplace insert assembly: The fireplace insert can be placed on a fitted base after the making of the thermal insulation as in the installation instructions. The fireplace insert is connected with the chimney by the connecting piece (smoke flue).
- Extension joint: It is necessary to have an extension joint at least 3 mm thick between the insert and the coating. The extension joint can be stemmed by a rope or sealing tape. For fireplace inserts with pull-up system door, there must be extension joint between veneer and moving parts min. 5mm. It is necessary to prevent the restriction of final position by veneer.
- Coating (fireplace surround): The coating of the fireplace insert which leads into the room must be made of non combustible material of grade A1 (e.g. tiles, plaster coat, iron or ceramic tiles). There must not be any direct contact between the coatings and the fireplace insert. The coating may overlap only on the separate carrying frame which is clamped to the wall. For adjustment, maintenance of a safety valve, a pump and accessories or possible repairs it is necessary to provide the surround with service holes. These holes are necessary for these operations and it is not needful to build the surround.
- Ornamental beams: Ornamental beams are allowed in front of the fireplace coating at a distance of 1 cm at least if the ornamental beam is not a part of the building and the intermediate space is such that it does not accumulate heat and the ornamental beam is not situated within the area of the insert heat radiation (see p.5).

pic. 05

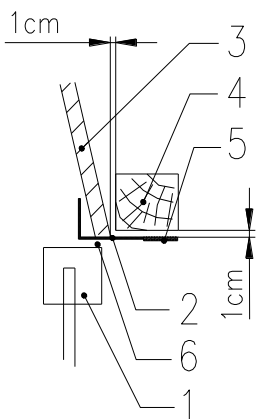

pic. 05 – position

- 1 – fireplace insert
- 2 – support frame
- 3 – veneer covering
- 4 – ornamental beam
- 5-heat radiating protection
- 6- extension joint

pic. 06

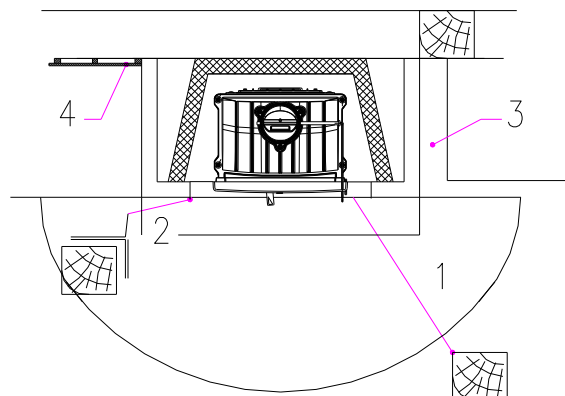

Fire protection in a heat radiation area



A minimum distance of 80 cm forwards and sideways must be retained in front of the fire box hole (pict.06, position 1). If the protection against heat radiation is from both sides, a distance of 40 cm is enough (pic. 06, position 2).



Fire protection above a heat radiation area

A minimum distance of 5 cm from the outer space of the insert coating to non-combustible building panels must be retained. Air space must be clear so as not to accumulate heat (pict. 06, position 3). Building panels covering only small coated areas of the fireplace insert, e.g. floors, wall coating and thermal insulation layers may abut onto the coating (pict. 06, position 4). Wider combustible building panels, e.g. ornamental beams, may be at a distance of 1 cm from the insert coating (see Ornamental beams).

External combustion air income

Hot air fireplace inserts are adjusted for direct connection for external combustion air inflow. Bellmouth of diameter of 120mm for external combustion air connection is ending on the back side (or bottom side) of the fireplace insert. Inflow for outdoor air connection for combustion in a fireplace insert must be as short as possible and must have few bends. For air inflow within the distance of 1.5 m with one bend (max. 90°) it is possible to use a pipe of diameter 100 mm. For air inflow within the distance of 3 m with one or two bends (total disjunction of angles 135°) it is possible to use a pipe of diameter 125 mm. When longer distance and more bends, it is necessary to take into account air resistance caused by friction of tube walls.

It is possible to supply hot air fireplace inserts with automatic electronic regulation of the combustion process. Automatic regulation consists of control unit, control damper and temperature sensor. Control damper must be situated in supply pipes, as close as possible to fireplace insert and connect hermetically onto bellmouth of the air inflow. After building of the fireplace, the damper must be accessible for service. When automatic regulation is in use, it is convenient to set up the hand-operated element in the 2/3 open position (providing right proportion of the air for nominal output of the insert). Also, fireplace insert can be fitted with door contact for easy service (position of the door contact is described below in paragraph “door adjusting and unhangng). More detailed description of connection and installing you will find in installing document of Automatic regulation.

When automatic regulation is in use, manually operated element must not be closed!



Firebox running

Hot air fireplace inserts are suitable either for closed or for open spaces.



Fireplaces with open hearth must be supervised all the time to prevent dangerous sparks and falling out wood pieces burning.



Fuel

Fireplace inserts can be operated only with the following fuel:
dry wooden logs



***ONLY DRY WOOD LIBERATES LITTLE HARMFUL POLLUTANTS DURING BURNING!!!
A fireplace insert is not suitable for waste burning!!!***



Combustion air input

It is necessary to supply a sufficient amount of external air into the room when using the fire. Both open and closed fireplaces require an adequate amount of fresh air. The steps for combustion air input cannot be changed and combustion air inputs must be open during the working operation of the firebox.

Convection air



To prevent heat accumulation, the incoming and outgoing grates of convection air must be open when using the fire. To prevent heat accumulation in heat distributing system, length of horizontal distribution piping must not be longer than 2,5m. The piping must always lead up. Exit can't lead vertically down.



We recommend ordering a professional firm to install hot air piping!

Fire protection above a heat radiation area



A minimum distance of 5 cm from the outer space of the insert coating to non-combustible building panels must be retained



Fire protection in a heat radiation area



A minimum distance of 80 cm forwards and sideways must be retained in front of the firebox hole - (furniture, carpets, plants etc.)



Protection against injuries

Do not forget that heaters have hot surfaces. Use the enclosed protective glove when working with the fire. You could be in a heat radiation area (80 cm) only during mending, and if there is further contact, the skin can be burnt. **Keep the fireplace out of the reach of children.**



Application and activation

Acceptable fuel, economical and ecological operation:

The fireplace insert is designed to use wood as fuel. The water content is max. 30% of dry weight. Logs should be stored in a dry and well ventilated place for two years. Using excessively wet logs leads to smoke with a tar condensation which could damage the chimney. In any case there is excessive environmental pollution. Logs should be 30 cm.

Wood is a very gaseous fuel and needs a lot of secondary air. Regulation with the help of slow or permanent burning is not possible with this kind of fuel. Heating output during wood burning is determined by the amount of the fuel used.

The most ecological and economical is dry wood burning because the heating quality of fresh wood is lower than that of dry wood.

As for burning waste, it must be stressed that burning material such as plastic material, cardboard, painted wood, etc. are harmful for your fireplace insert and furthermore is prohibited by the Emission Act. It is allowed to use firelighters, paper and small wood for lighting a fire only.



Do not use combustible liquid e.g. petrol, alcohol for lighting a fire and do not store similar kinds of liquid near your fireplace insert!



The first lighting

The fireplace insert should start with a small fire at first, so as not to harm it by very fast temperature rise. Smoke and the smell of burning which may appear during the first lighting of a fire is a result of coating thermal curing. The room should be well aired during first heating.



Before the first use, check if all removable parts of the fireplace (block, deflector, grate and ash hole) are in the right position – in accordance with the Equipment Certificate.



Lighting a fire

Stoking a fireplace insert is operated through a firebox door. At first bank up the fire with 2 big logs on the bottom of the firebox, then 2-3 smaller logs across (1,5 to 2 kg of wood). Then add some paper, paperboard or firelighter, then wood chips and finally small pieces of wood. Set on fire and open all air inflows at maximum (open fully air input or keep the front door little bit open). When the fire is burning well, close the door and regulate required output. When wood is white-hot, burning down, stoke fuel again when there is high heat inside.



***The optimum amount of fuel is recommended in the Equipment Certificate.
Due to overloading of the insert, nonreturnable changes will occur!***



We can provide a guaranty for our products only when the insert is not overloaded and service instructions are kept!

Fireplace insert with chamot lining:

Chamot parts need to be heated up very slowly. Big temperature changes can cause cracking of the chamot parts. The broken chamots do not affect the function of the fireplace insert. In case of broken chamot, special paste is supplied by manufacturer to fill it in.

It is important to use dry wood only (max 20% of humidity). In other case fire-bricks are overloaded, the amount of ash is bigger and the wood is not fully burnt.

Common defects:

- Grate deflection or any other part– indication of the insert overloading
- Chimney valve immovable – mechanical changes at shaft due to overloading
- Deflection of exchangeable parts – indication of insert overloading
- Problems with door sliding – when happens mostly during burning, overloading indication
- chamot broken – do not affect the function of the fireplace insert, indication of bad use
- bubbles in the glass – up to 5 mm it is not an aesthetic or a functional defect



***The fireplace insert is overloaded when the big amount of fuel is added.
The recommended one-hour fuel flow is written in the Equipment certificate.***



Setting of air inlet during hands-off operation

Hot air inserts are provided with the air input in bottom part underneath the door. With the help of this regulation you can regulate combustion air input (primary air) and also the glass flushing. The proportion of the air amount in each intake is regulated automatically. There is a possibility of nearly closing of the regulation for long term operation.

Fuel addition

Apart from using the suitable fuel and having an adequate chimney draught, the clearness of the glass front is influenced by the way the fireplace is used. It is recommended to add only one layer of fuel. About 5 - 10 seconds before you open the firebox door you should close the discharge valve (engaged position – closed, disengaged position – open), to stop smoke leakage from the firebox to the room. After adding fuel close the firebox door again. Then open all the discharge valves to reduce the rate of fuel burning. When fuel burns, change the regulating again as above.



WARNING: DO NOT CLOSE INTENSELY AND AFTER THAT DO NOT OPEN INTENSELY EXTERNAL AIR INPUT, THERE IS A POSSIBILITY OF EXPLOSION OF ACCUMULATED UNBURNT GAZES!



Open fires

Open fires must be supervised constantly!



Add only one fuel layer into the firebox so as not to overhang the barrier in its front part. Add only the recommended amount of fuel. The fireplace must not run with any other kind of fuel.



Ash removal

At least once a day it is necessary to remove ash, with the help of a clinking bar, from the bottom part of the fireplace insert. The best time is in the morning because of the relatively cold state of the fireplace. It is possible to put wooden ash on compost or to use it as manure. Fireplace inserts without grate: the layer of ash mustn't reach the edge of the door. If the fireplace is covered with a layer of ash, there is a risk of falling embers from the fire.



*Before emptying of ash make sure, that there are no cinders in it.
Even with cold ash it is possible to find embers which can cause a fire in an ash bin.*



Cleaning and maintenance

You should clean your fireplace at least twice per heating season or if needed. Clean it when it is cold. The most important for cleaning are tubes of exchanger and smoke flue bend. For cleaning, you need to remove deflectors – see below and brush properly all tubes with brush of Ø70mm. Remove covering of the bend and clean the smoke flue. The best way how to clean the glass is to use a special cleaner for glass (do not use any cleaners with an abrasive action!).

Service opening door for cleaning

The corner fireplace inserts with sliding door – for cleaning, the door is possible to open sideways, around the hinge. Before opening, it is necessary to pull out the stop safety lock (1). Then, you unlock the locks on the top and bottom door parts using the special key (provided with the insert)(2) and open the door. When closing the door, it is necessary to make sure, the 2 safety locks (3) are fully clipped in the door slots and it is necessary to lock the door with the provided key again.

For flat door inserts with sliding door system, the door is open towards to you for cleaning. You unlock the lock (4) on the top door part using the loop. In the cleaning position towards to you, the door is supported with stop drawbar (5). For closing the door again, you only push and click strongly the door back.

For normal opening fireplace inserts, opening sideward, it is possible to unhang the door for better cleaning – follow the pictures under.

Corner door lock

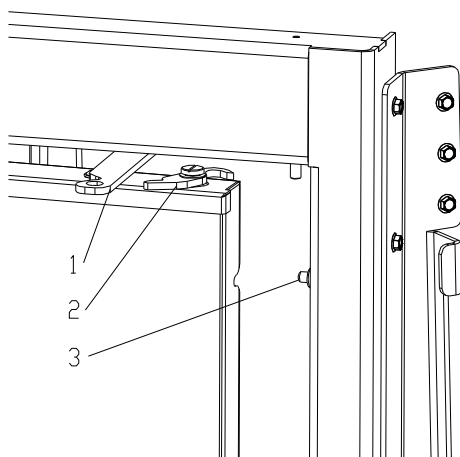

Flat door lock

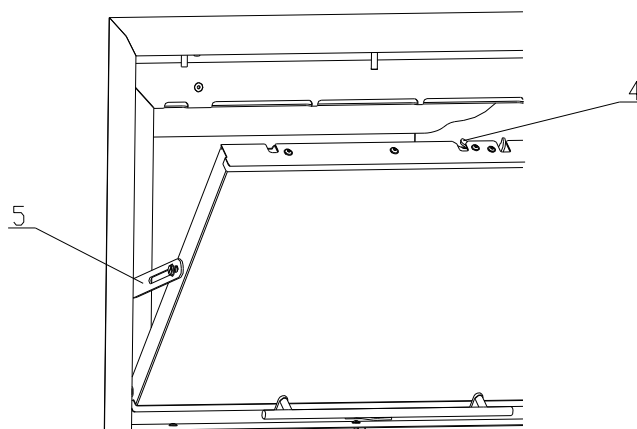

Door adjusting and door unhooking for service

The front door is possible to unhook for more comfortable cleaning and service. First throw up safety pin on the top hinge (1). After, the door can be uplifted and be unhooked from the fireplace insert (2).

The door adjusting is possible due to adjustable bottom hinge. After dismantling of the frame (3), loosen two screws M6 on the bottom of the frame (4) and move hinge into the position requested. For easy access to screws of the hinges it is necessary to keep space between veneer and bottom part of the frame see pict.5. This space is important for additional demounting of door contact.

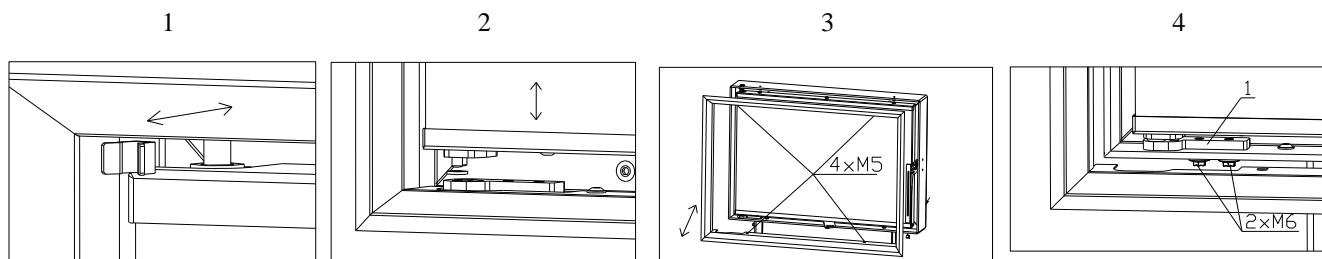

1 – Hinge

Adjusting of the door pressure:

Due to 2 screws M5 (pos.1), it is possible change the position of the hung of the door frame. It is possible to change the pressure (increase or decrease) because of the replacing of the sealing insulating tape.

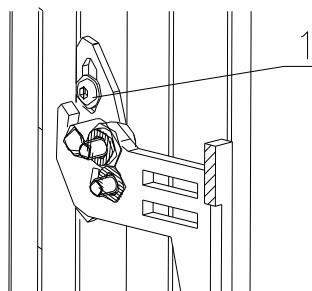

BeF
home

BeF Home, s.r.o.
Kotvrdovice 277
679 07 Kotvrdovice
Tel. 516/428 240
Fax. 516/428 244
IČO: 255246